

## AIR AMPLIFIERS

Blowoff, clean, cool and dry as well as vent and exhaust with no moving parts

### WHAT ARE THEY - REASONS TO USE

Air Amplifiers or “Air Movers” are a simple, inexpensive device with virtually no maintenance that can convey fumes, smoke, light weight materials, and move a high volume of air for cooling, blowoff and drying applications. They use the “coanda effect” which entrains a large amount of surrounding air using only a small amount of compressed air. The effect is an amplification of up to 17 times the airflow or more (depending on the size) with reduced noise levels. Using only compressed air, the output flow and vacuum is easily controlled by adjusting or opening the air gap and/or inlet pressure. Either end of the amplifier may be ducted to address all kinds of applications from bringing in fresh air into an area to removing nasty fumes. Be wary of extremely high unrealistic or unsubstantiated amplification ratios claimed by some companies.



### TYPES OF AIR AMPLIFIERS



**STANDARD “FIXED” AIR AMPLIFIER:** made of zinc die cast system is solid and perform as well or better than many supposedly patented designs when used in similar applications. The gap can be adjusted by adding shims. Five sizes are available.



**ADJUSTABLE AIR AMPLIFIER:** made of anodized aluminum or stainless steel for high temperature or food applications. The customer can set the gap and lock it in place using a lock ring. Three sizes are available.

### SPECIAL DESIGNS

Special designs are available to meet unique customer specifications. Specially treated stainless steel units have been made for a specific medical application and threaded adjustable versions have been made for a machine builder. Different materials can be provided as well as special sizes to fit any specific application.

### AIR AMPLIFIER FEATURES:

- ▶ No moving parts.
- ▶ Compact design, simple, lightweight and portable.
- ▶ Driven by air not electricity.
- ▶ Replaces fans used for blowoff, cleaning, drying, cooling and conveying.
- ▶ High airflow amplification.
- ▶ Instant on-off, no electricity or explosion hazard.

### AIR AMPLIFIER BENEFITS:

- ▶ Longer life in difficult environments than competitive models.
- ▶ Lower compressed air consumption than ejectors and venturi.
- ▶ Maintenance free with output easily controlled, safe to use.

### AIR AMPLIFIER ADVANTAGES OVER FANS:

- ▶ Compact design, simple, lightweight and portable.
- ▶ Driven by air, not electricity for safety.
- ▶ No moving parts hence safer and maintenance free.
- ▶ Each end can be dusted for light conveying applications.

### SELECTION

Whether you choose a fixed or adjustable unit depends on the application. The fixed unit being made of heavy duty zinc die cast is more ideal in rough environments where corrosion is not an issue. The aluminum Adjustable Air Amplifiers are light-weight and flexible because of being adjustable. Stainless steel adjustable units are meant for corrosive environments and for food/pharmaceutical applications.



**STANDARD AIR AMPLIFIER - HOW IT WORKS:**

A small amount of compressed air enters the annular chamber at point (A). That is then throttled through a small ring nozzle at high velocity and into the inside of the Amplifier over a “coanda” profile. The compressed air stream clings to the “coanda” profile as it enters the inside walls of the amplifier and thereby creating a vacuum that induces the outside air at point (B). Converting the pressure into amplified airflow. The amplified airflow leaves at the exit at point (C). Airflow is further amplified downstream at point (D). By entraining additional air from the surroundings at the exit.

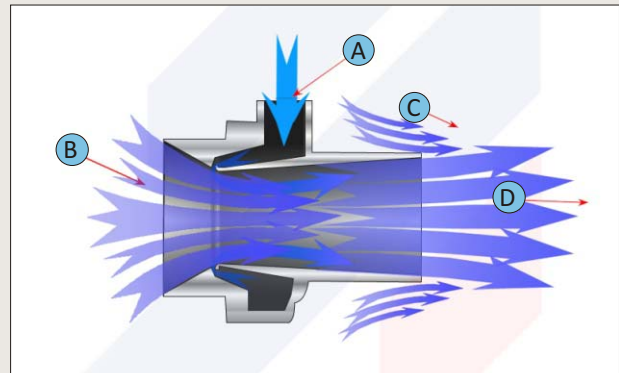

**AMPLIFIERS-RATIOS (APPROX.)**

Model AM10: 6.5:1
Model AM20: 14:1
Model AM40: 15:1
Model AM75: 15:1
Model AM125: 16:1

OUTSIDE DIAMETER OF OUTLET	OUTSIDE DIAMETER OF OUTLET	*A	B	C	D	E	F	G	H	I	J	K (NPT)
AM10	3/4"	0.39	1.30	0.98	1.77	2.28	0.20	0.16	0.59	0.73	1.55	1/8"
	19 mm	10	33	25	45	58	5	4	15	19	40	
AM20	1-1/4"	0.79	1.85	1.50	2.40	3.03	0.27	0.20	0.59	1.22	2.16	1/4"
	31 mm	20	47	38	61	77	7	5	15	31	55	
AM40	2"	1.57	3.15	2.95	3.58	4.13	0.27	0.27	0.78	2.00	2.91	3/8"
	51 mm	40	80	75	91	105	7	7	20	51	74	
AM75	4"	2.95	5.90	4.91	6.89	8.46	0.53	0.55	1.19	3.97	5.90	1/2"
	101 mm	75	150	125	175	215	13	4	30	101	150	
AM125	8"	4.92	10.39	7.08	-	-	-	-	0.79	7.79	16.73	3/4"
	200 mm	125	264	180	-	-	-	-	20	200	425	

\* Inside Diameter

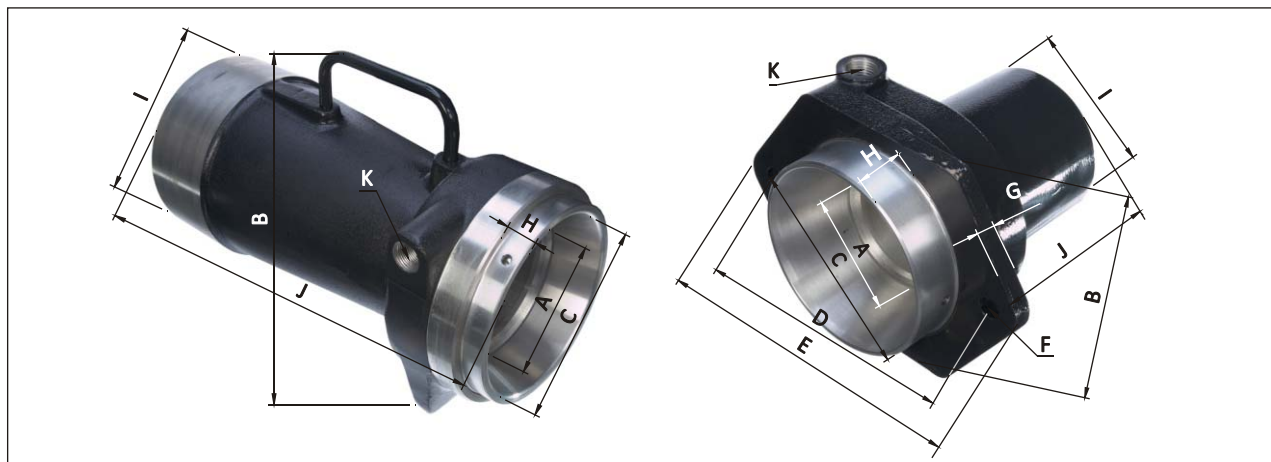

AM10

AMPLIFICATION RATIO = 6.5:1 (SEE ADDENDUM-I)

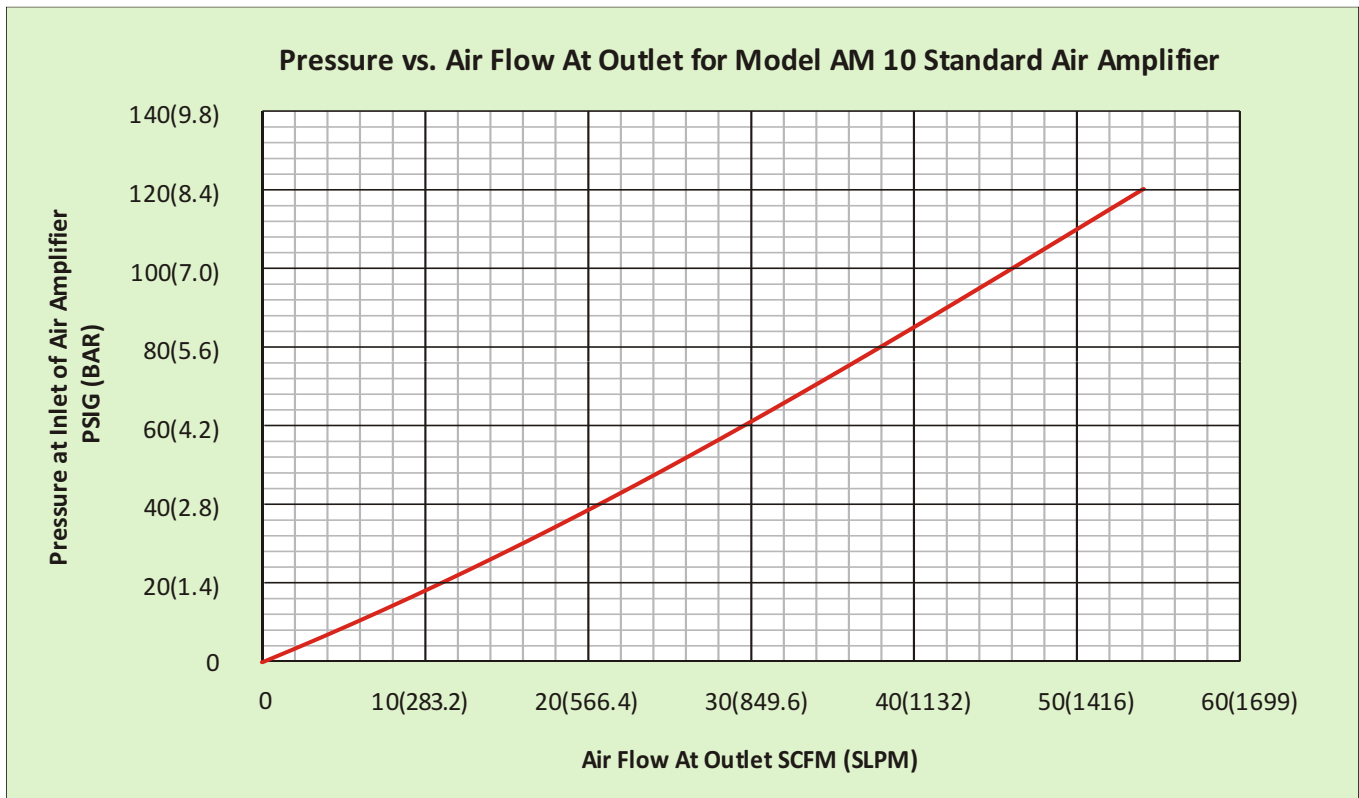
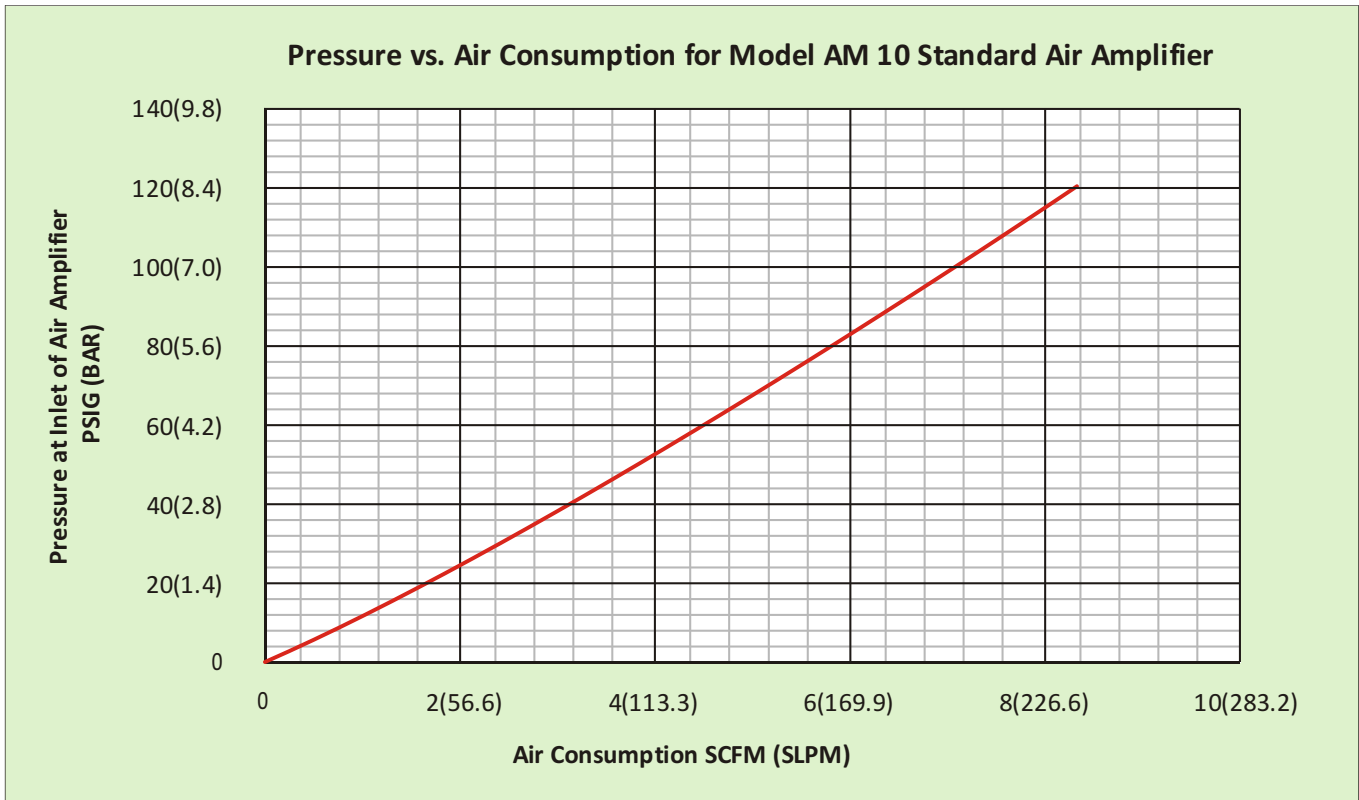

**AIR AMPLIFIERS**



**AM10**

**Pressure vs. Velocity At Outlet for Model AM 10 Standard Air Amplifier**

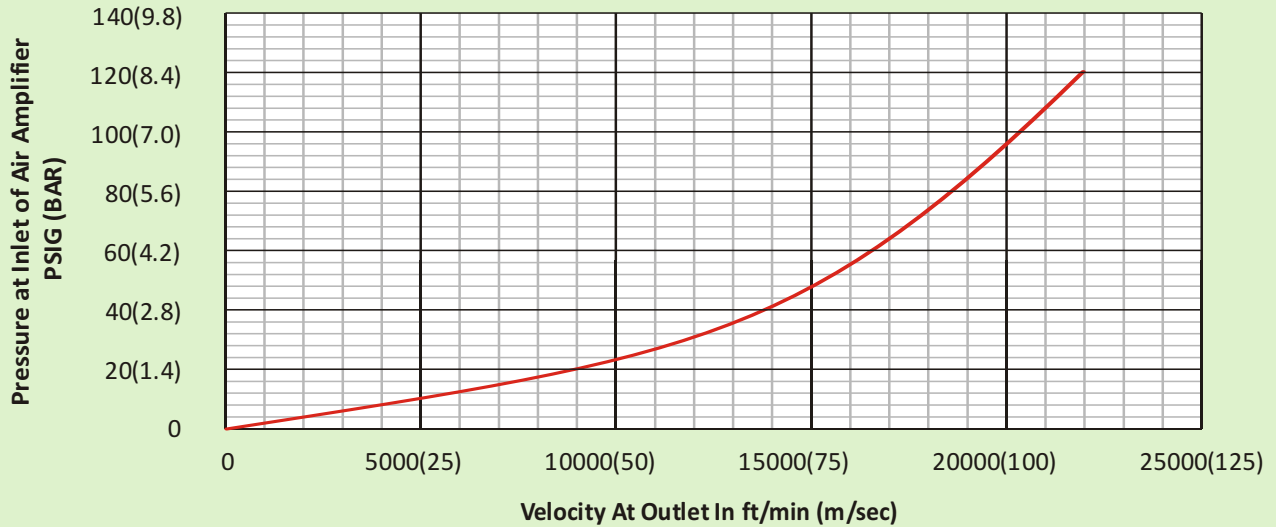

**Pressure vs. Velocity 6" From Outlet for Model AM 10 Standard Air Amplifier**

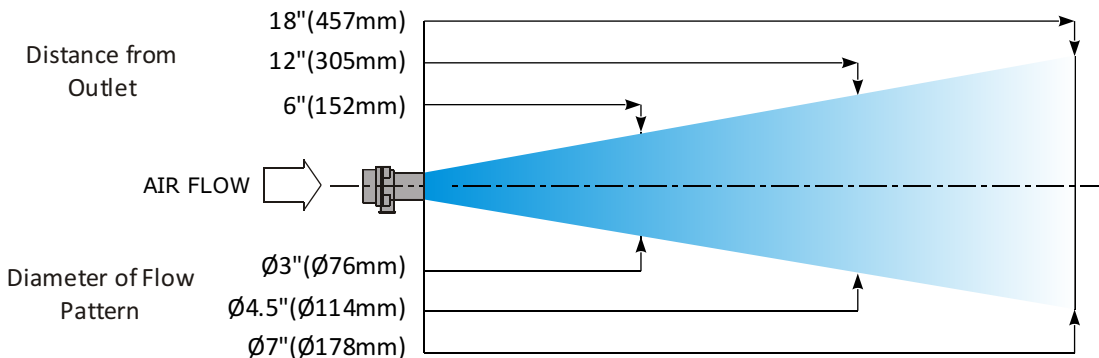
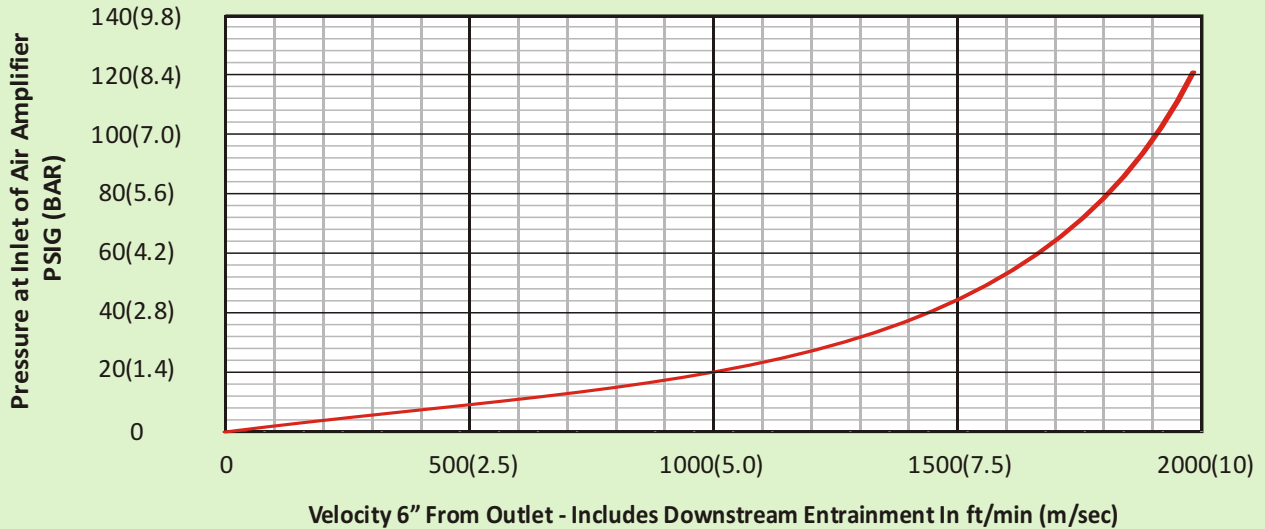

AM20

AMPLIFICATION RATIO = 14:1 (SEE ADDENDUM-I)

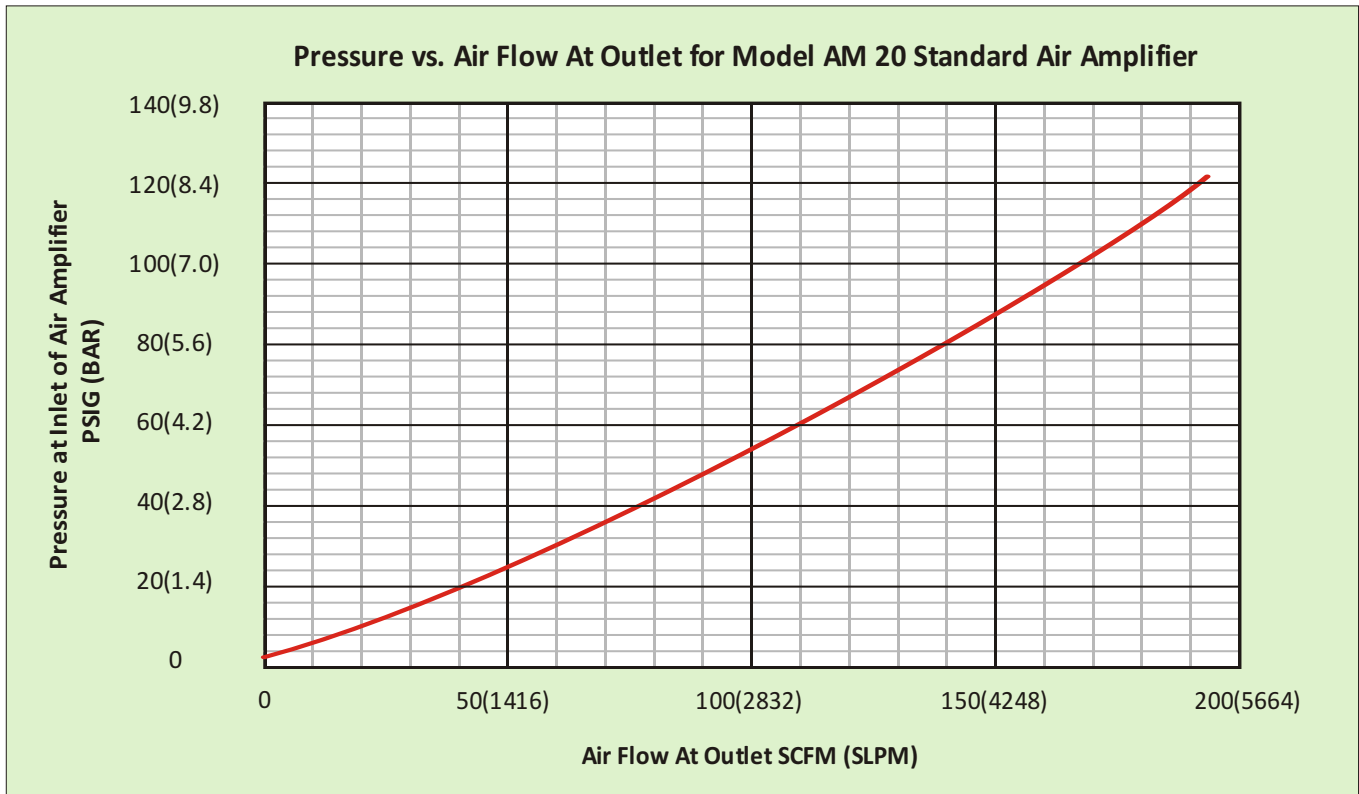
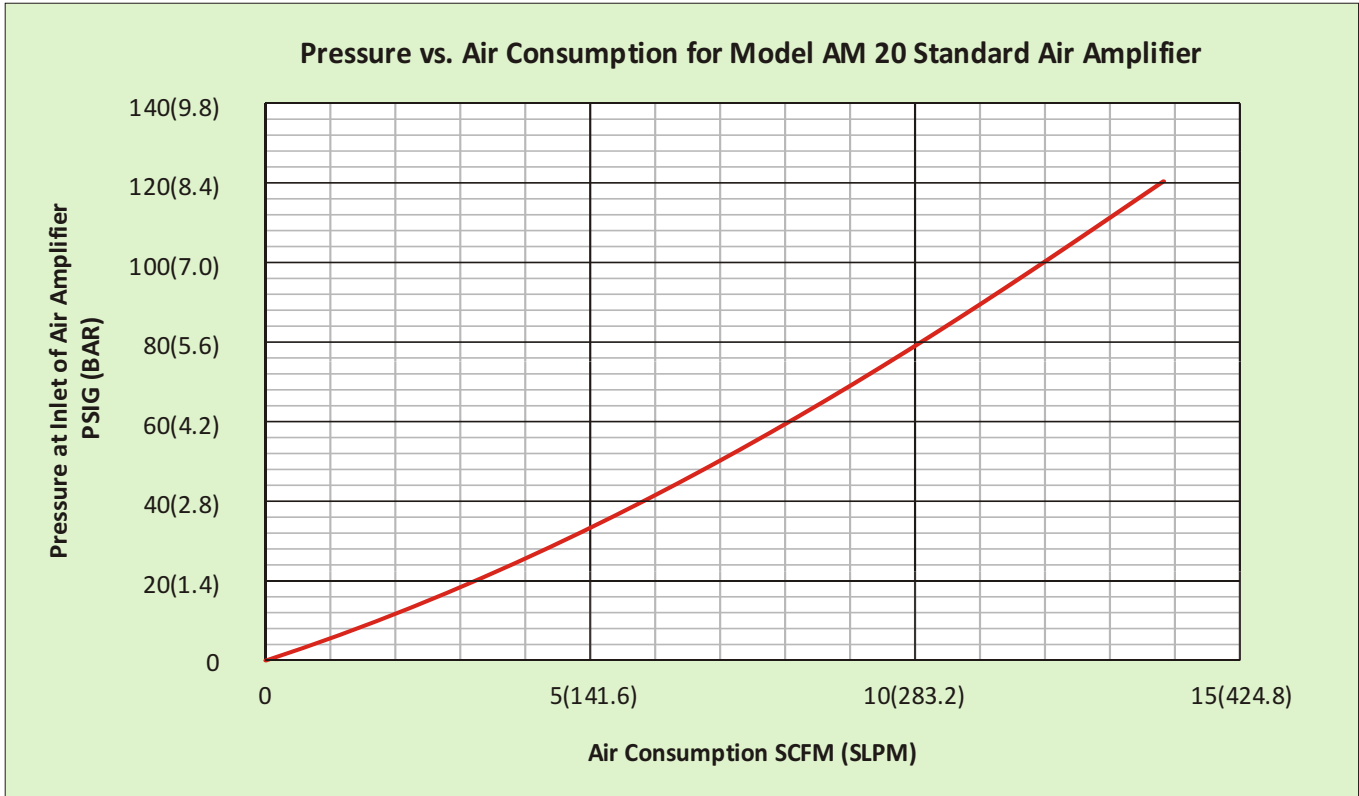

**AIR AMPLIFIERS**



**AM20**

**Pressure vs. Velocity At Outlet for Model AM 20 Standard Air Amplifier**

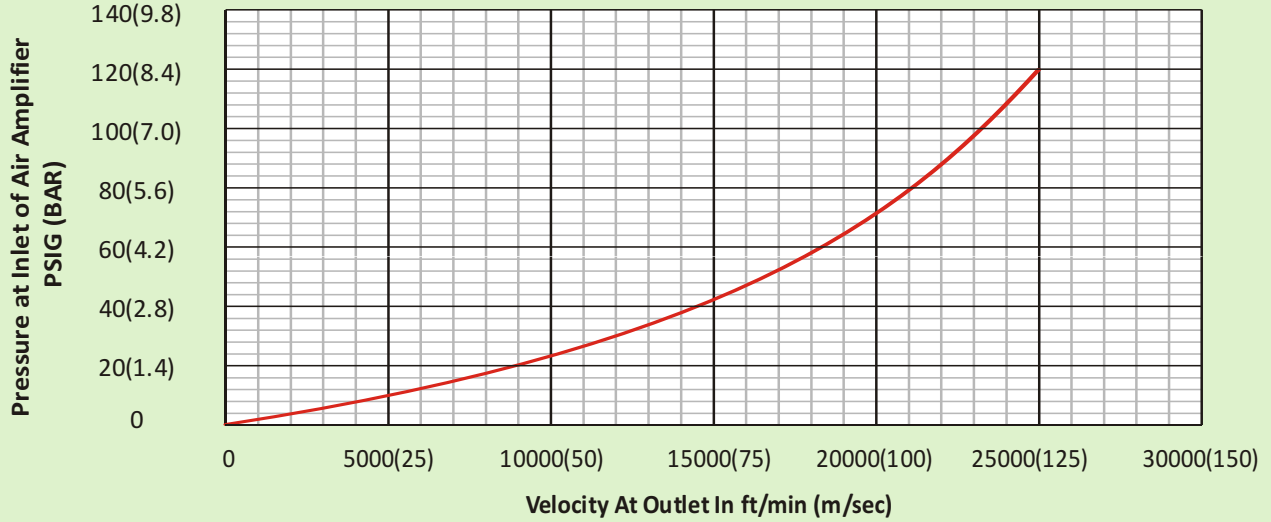

**Pressure vs. Velocity 12" From Outlet for Model AM 20 Standard Air Amplifier**

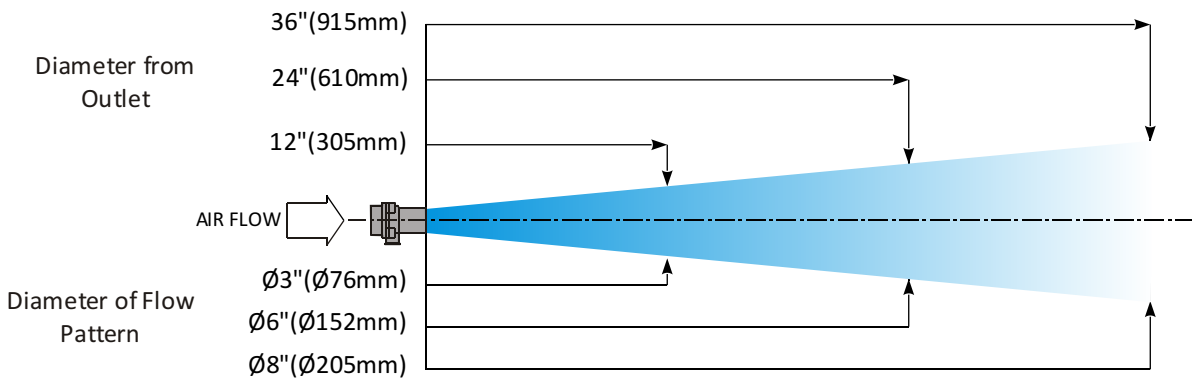
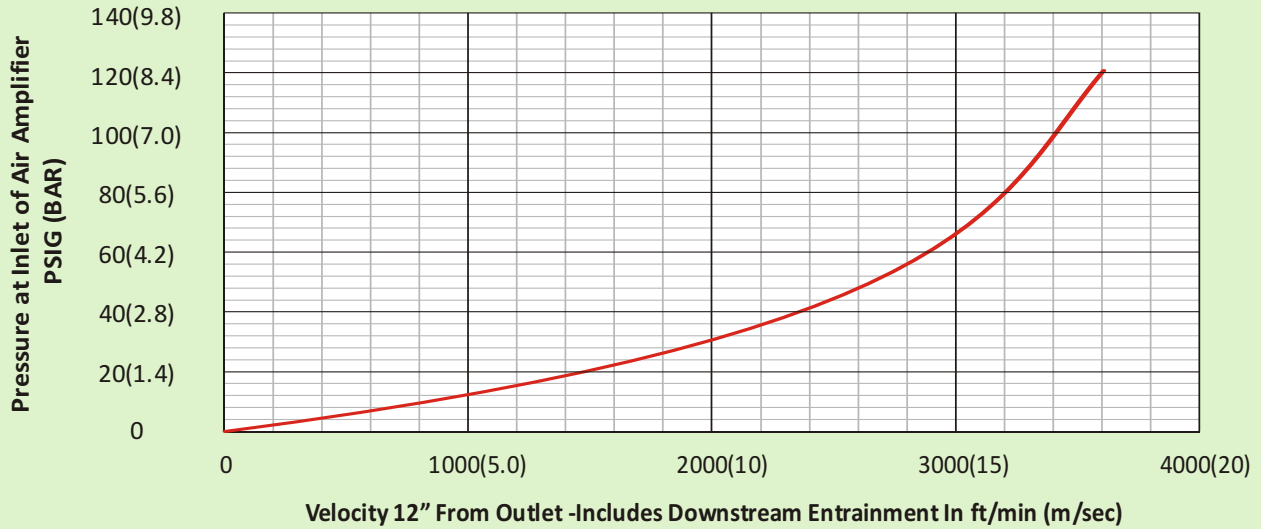

AM40

AMPLIFICATION RATIO = 15:1 (SEE ADDENDUM-I)

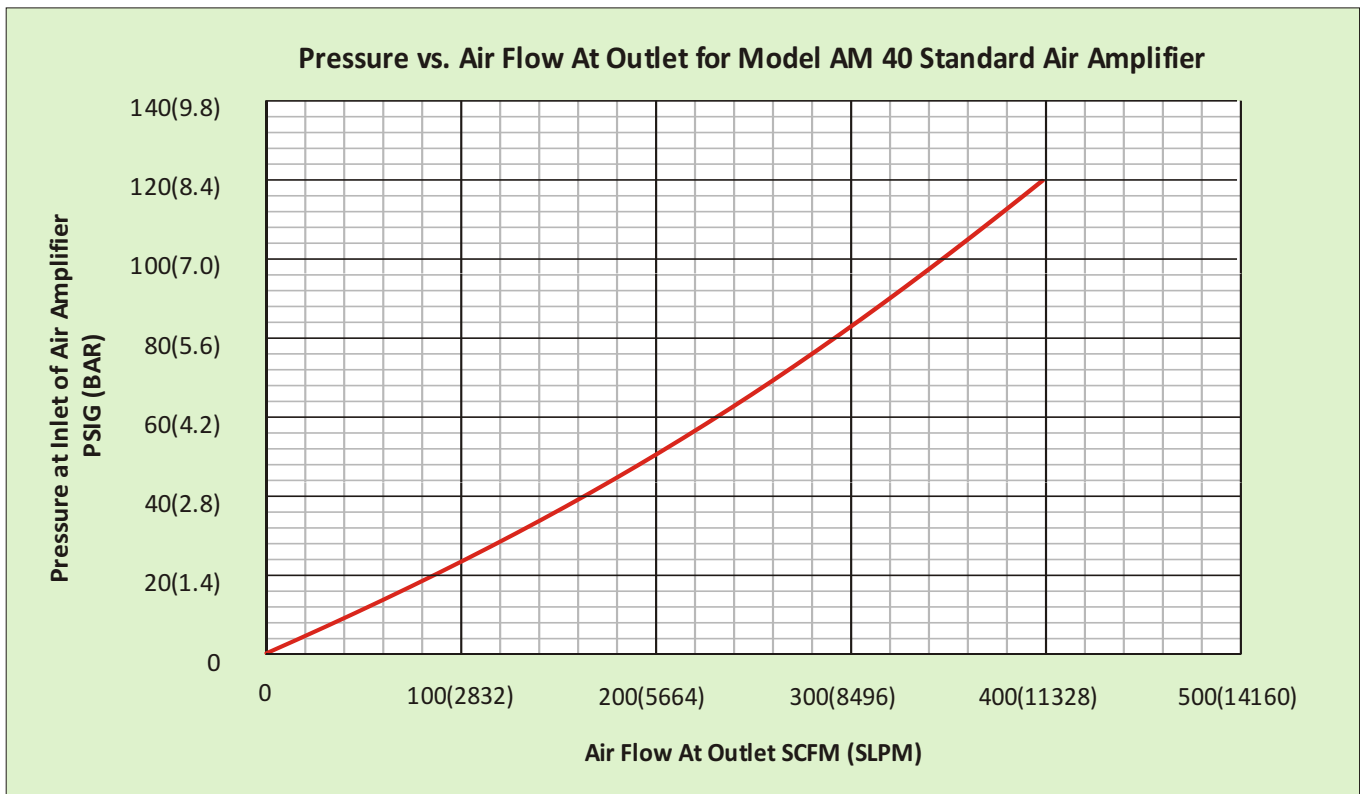
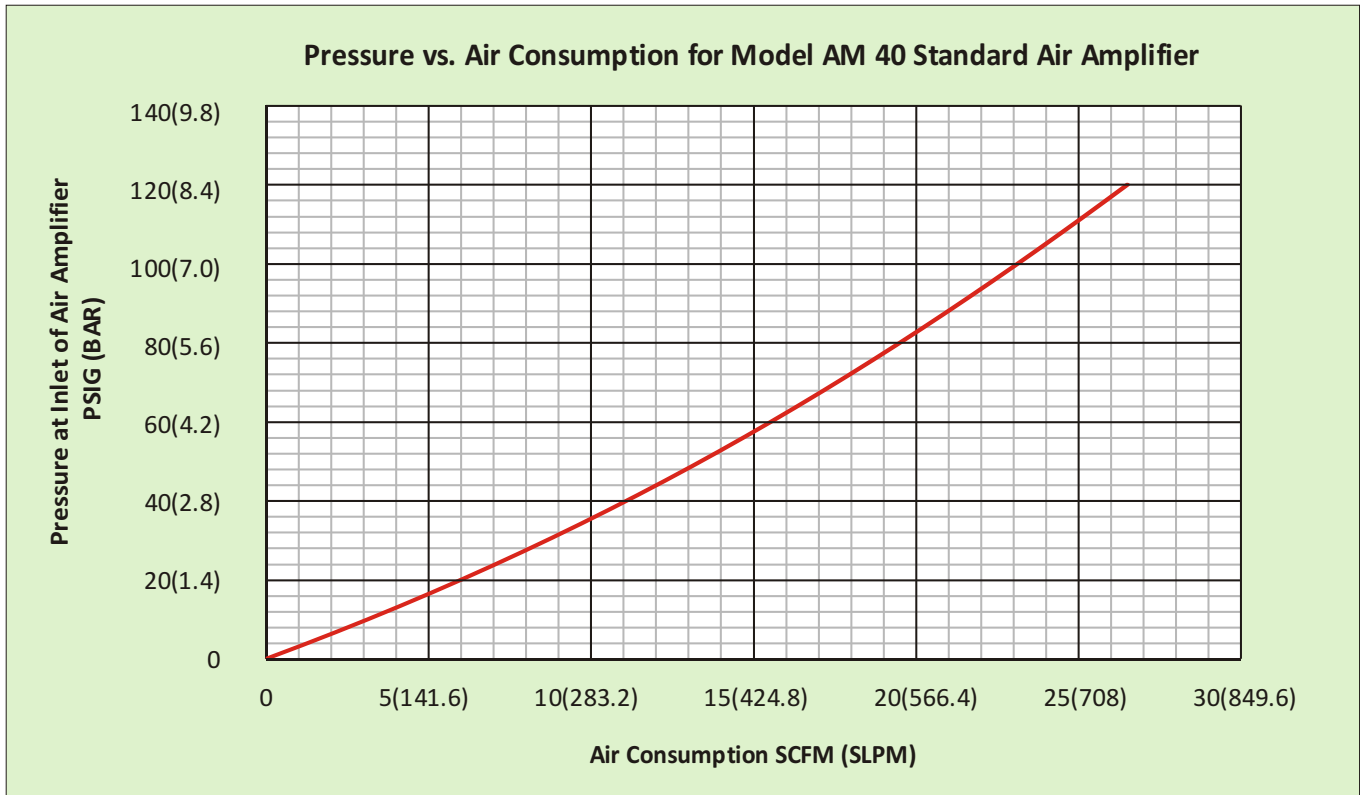

**AIR AMPLIFIERS**



**7 9**

**AM40**

**Pressure vs. Velocity At Outlet for Model AM 40 Standard Air Amplifier**

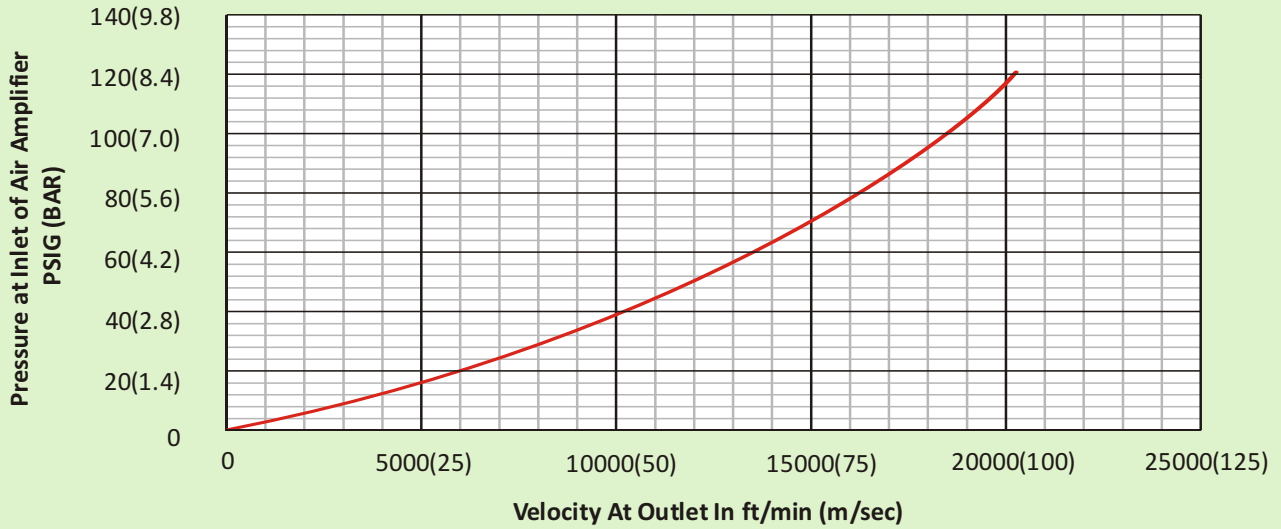

**Pressure vs. Velocity 12" From Outlet for Model AM 40 Standard Air Amplifier**

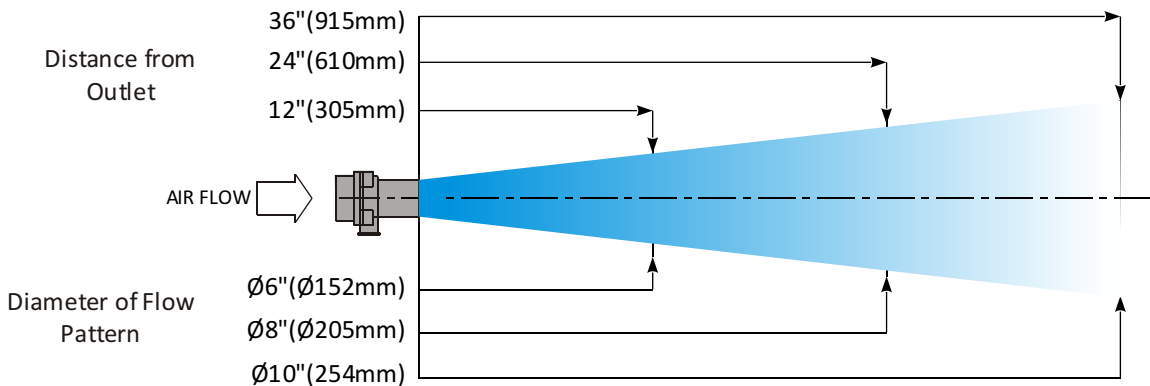
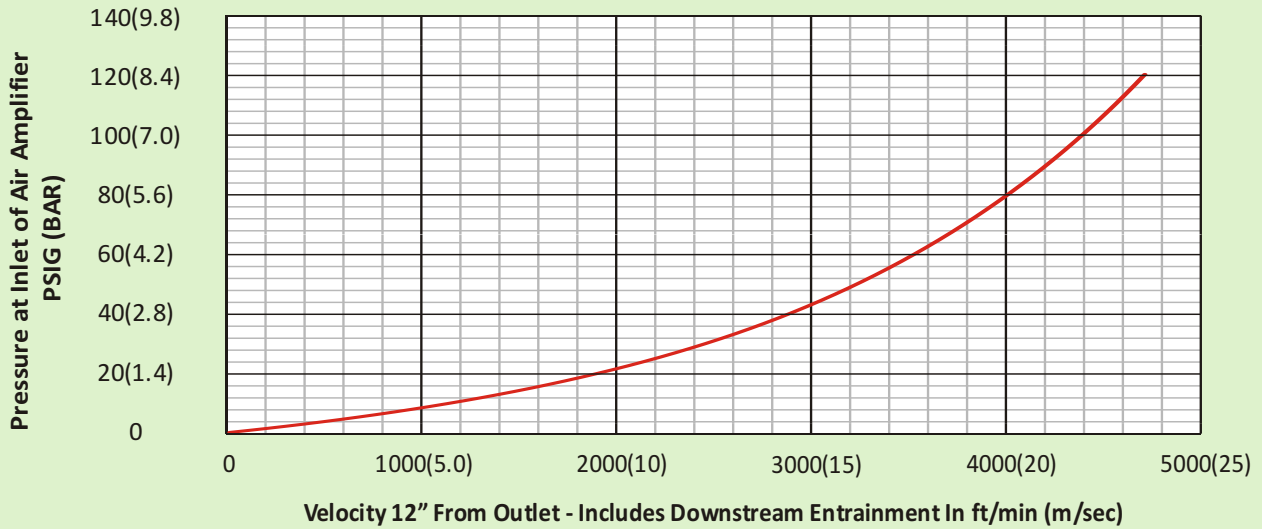



AM75

AMPLIFICATION RATIO = 15:1 (SEE ADDENDUM - I)

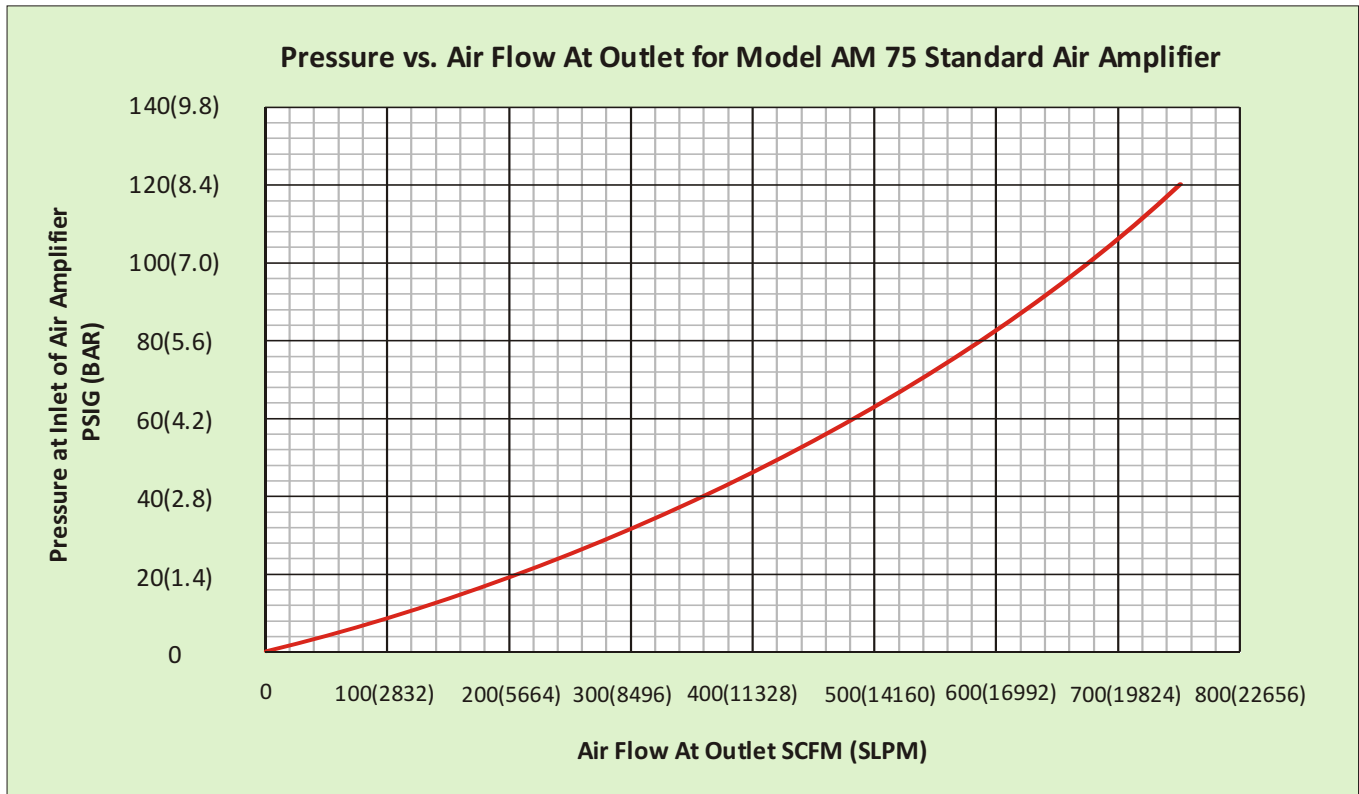
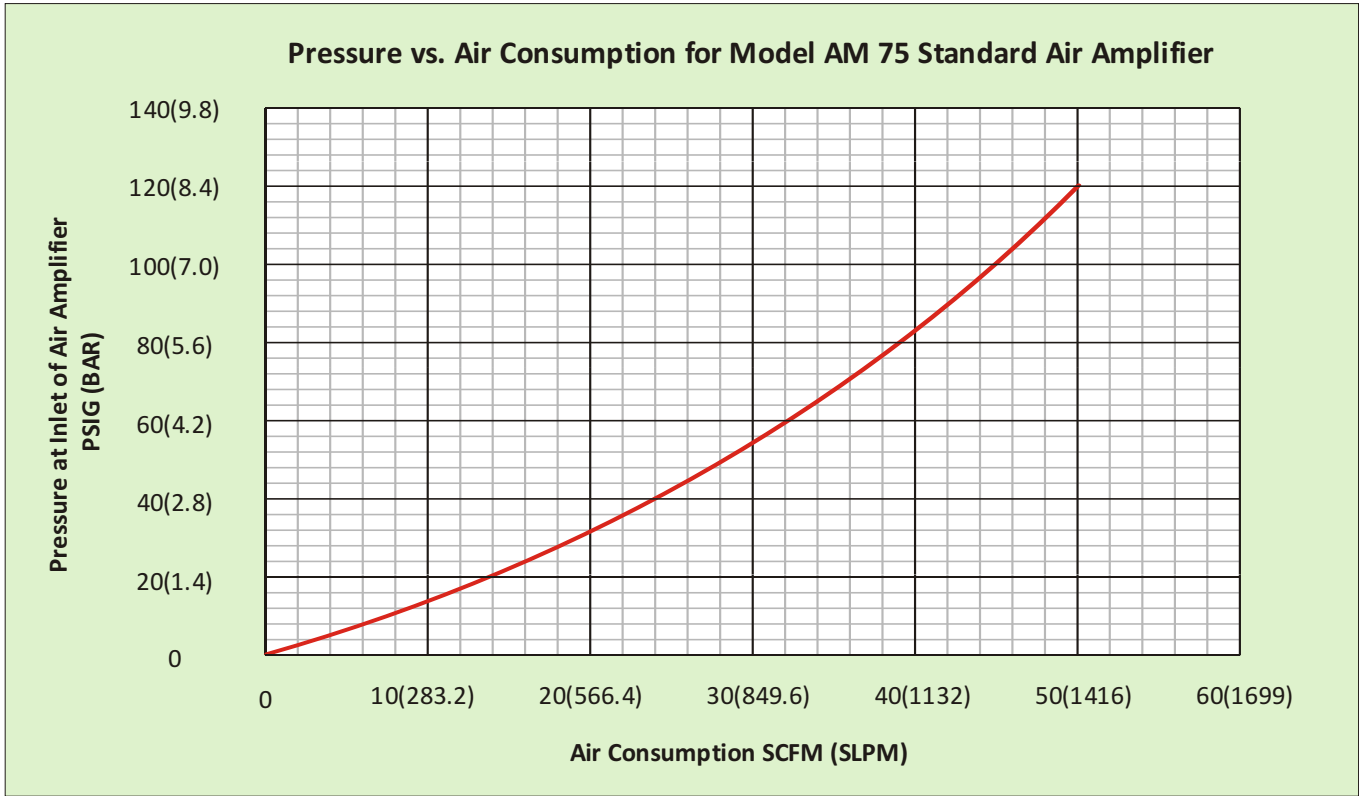

**AIR AMPLIFIERS**



**D 9**

**AM75**

**Pressure vs. Velocity At Outlet for Model AM 75 Standard Air Amplifier**

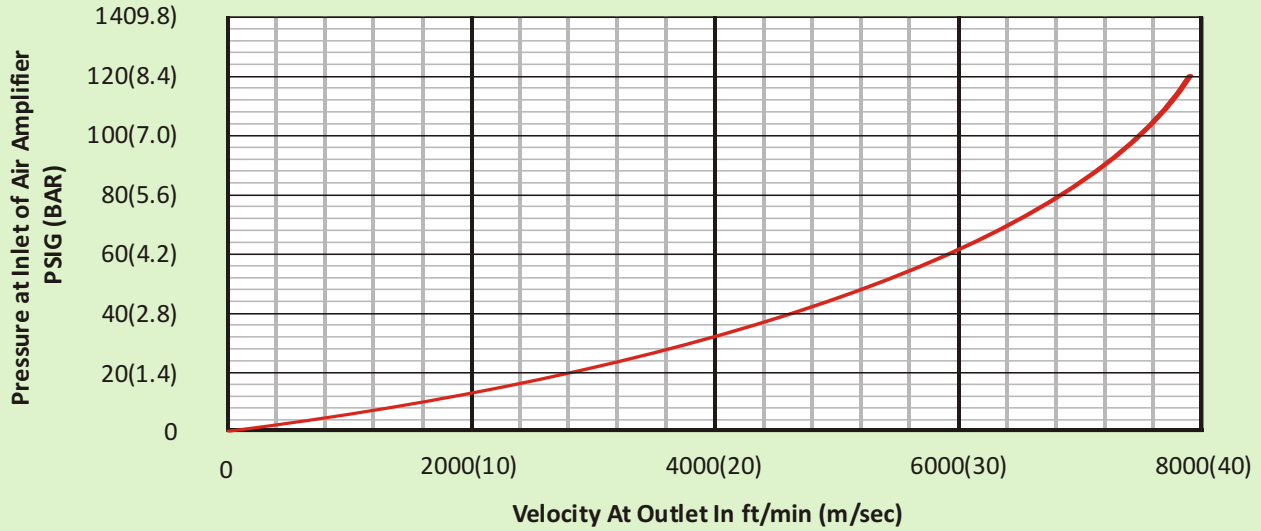

**Pressure vs. Velocity 12" From Outlet for Model AM 75 Standard Air Amplifier**

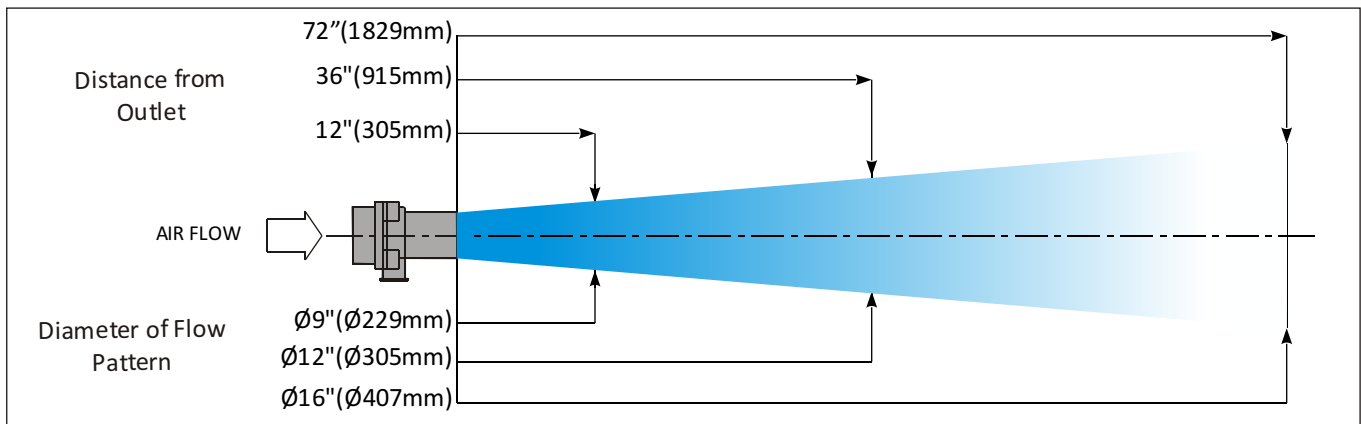
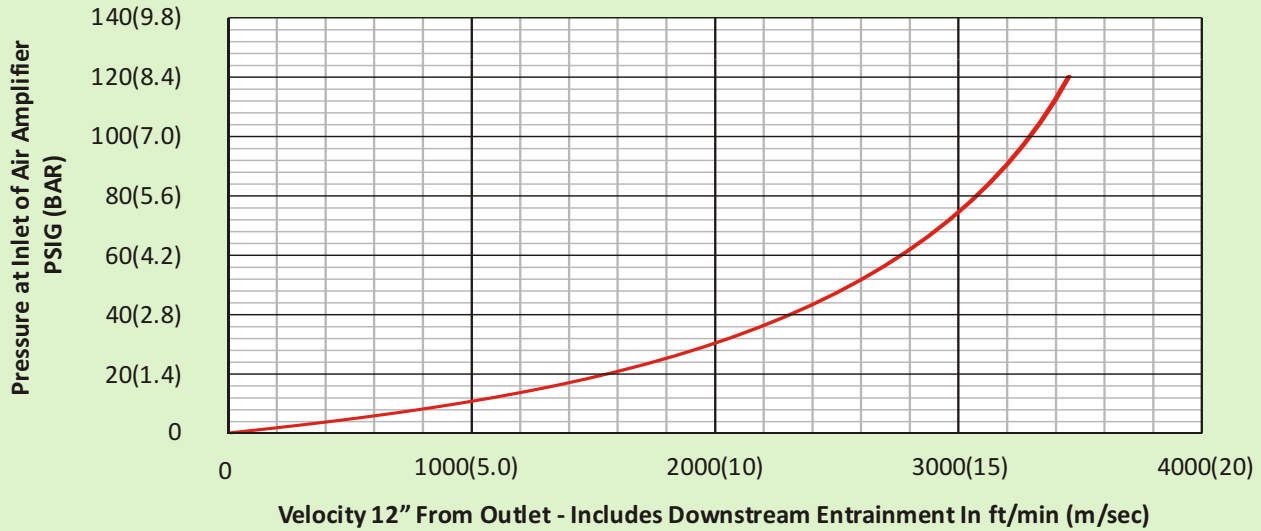

AM125

AMPLIFICATION RATIO = 16:1 (SEE ADDENDUM - I)

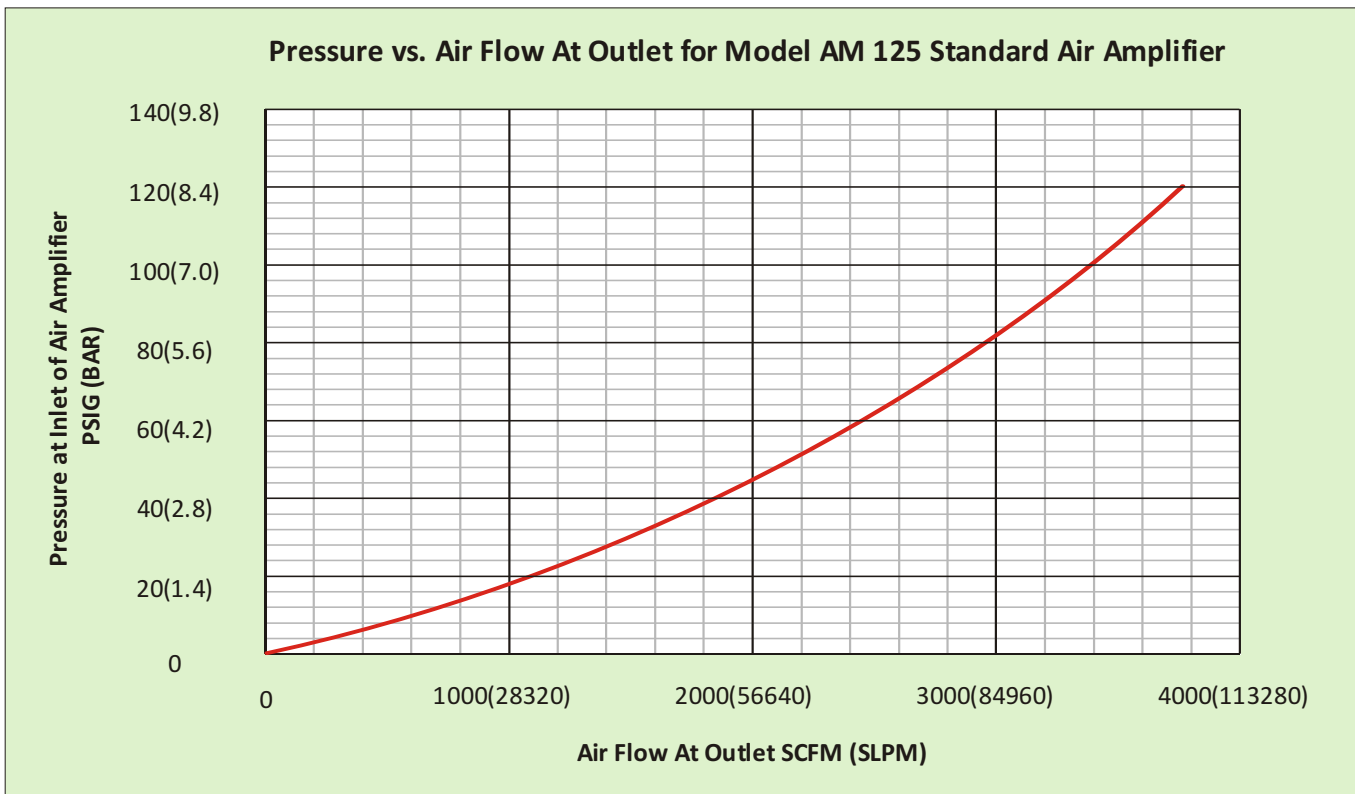
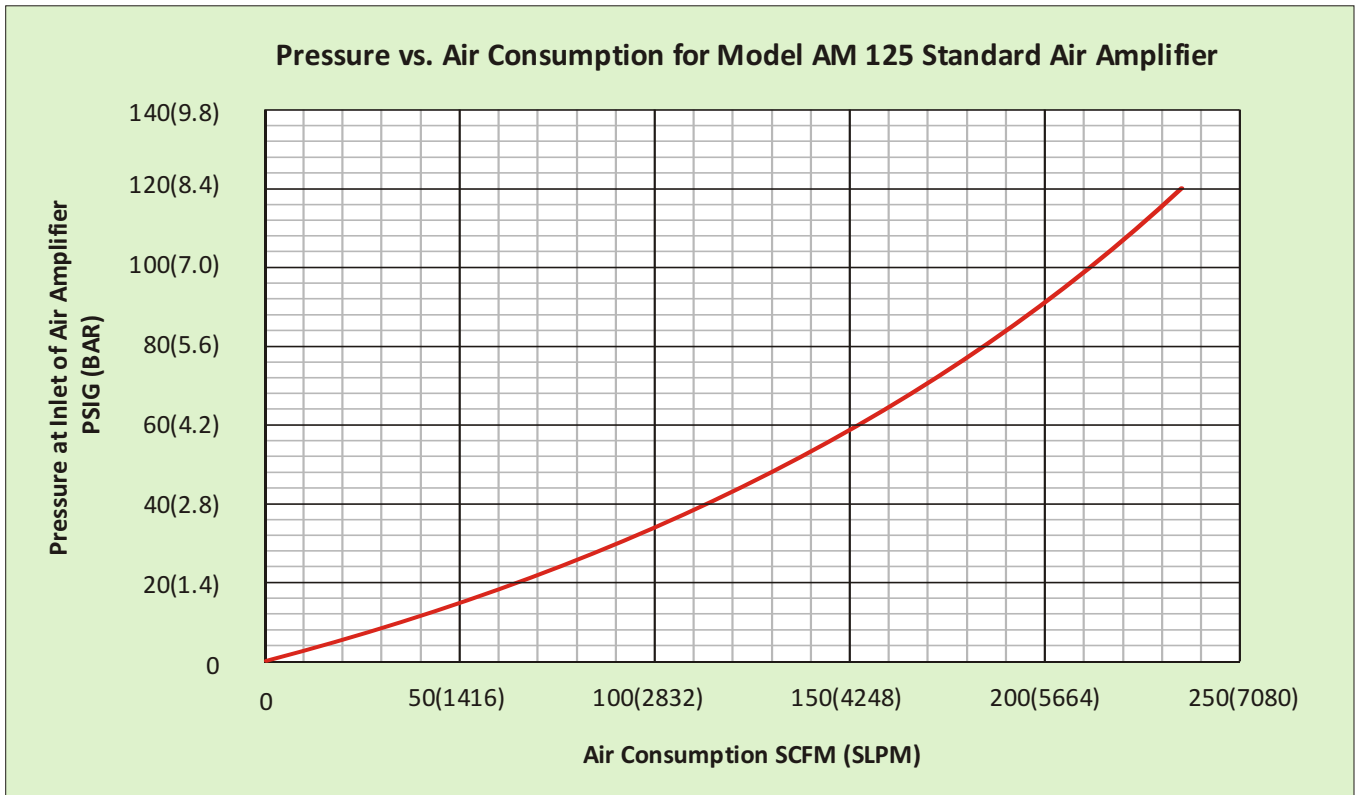

**AIR AMPLIFIERS**



**AM125**

**Pressure vs. Velocity At Outlet for Model AM 125 Standard Air Amplifier**

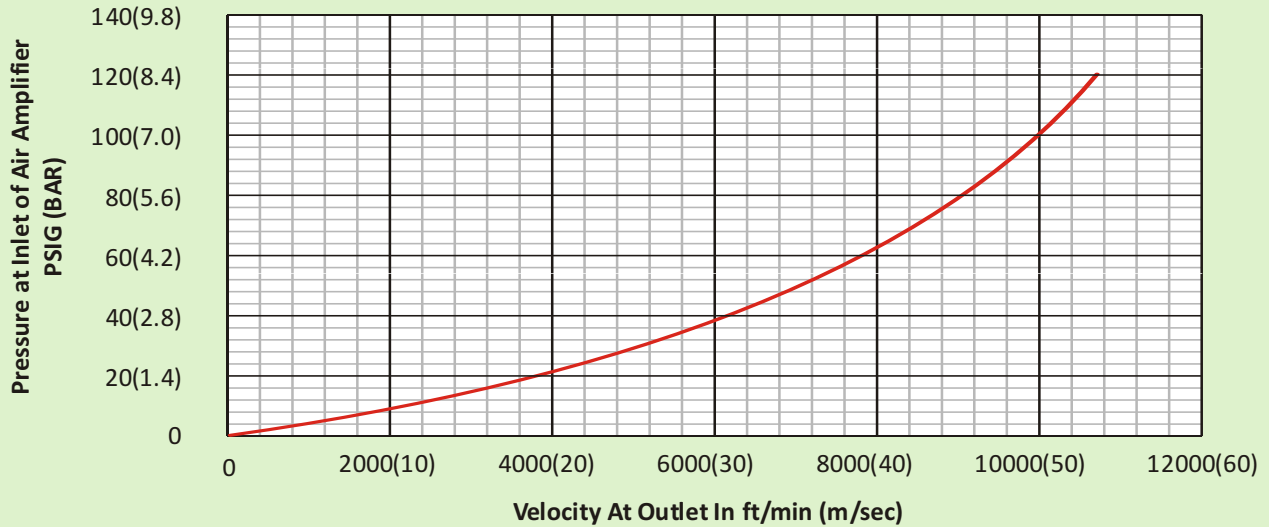

**Pressure vs. Velocity 12" From Outlet for Model AM 125 Standard Air Amplifier**

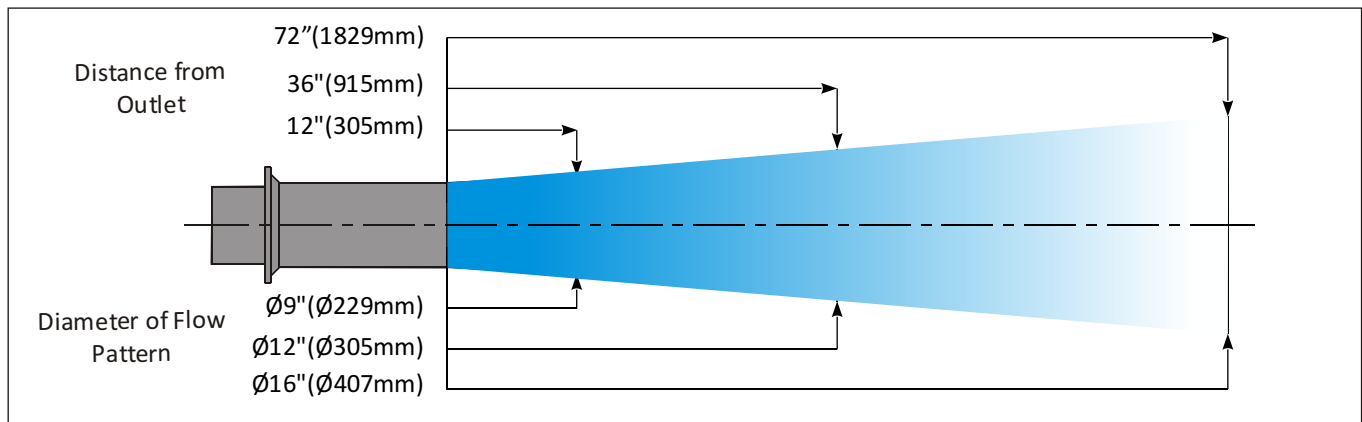
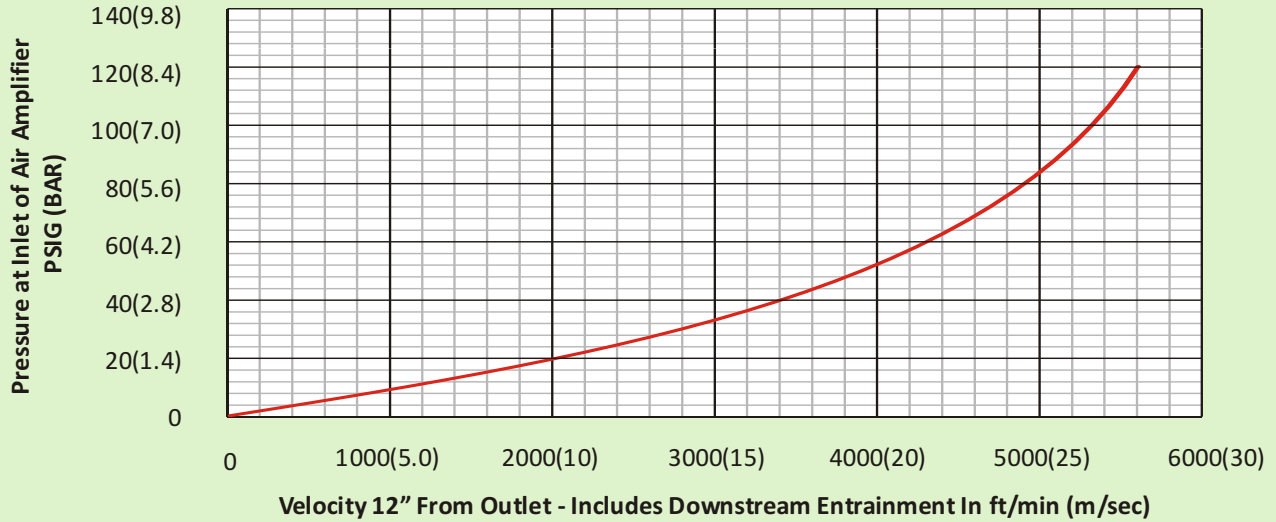

**CAST ZINC FIXED STANDARD AIR AMPLIFIERS**

PART NO.	DESCRIPTION
AM10	3/4" Zinc Alloy Amplifier
AM20	1-1/4" Zinc Alloy Amplifier
AM40	2" Zinc Alloy Amplifier
AM75	4" Zinc Alloy Amplifier
AM125	8" Zinc Alloy Amplifier
AM10-1	3/4" Amplifier plus Filter with Auto Drain
AM20-1	1-1/4" Amplifier plus filter with auto drain 2" Amplifier plus Filter with Auto Drain
AM40-1	4" Amplifier plus Filter with Auto Drain
AM75-1	8" Amplifier plus Filter with Auto Drain 3/4" Amplifier plus Filter with Auto Drain plus
AM125-1	Regulator with Gauge
AM10-2	3/4" Amplifier plus Filter with Auto Drain plus Regulator with Gauge
AM20-2	1-1/4" Amplifier plus Filter with Auto Drain plus Regulator with Gauge
AM40-2	2" Amplifier plus Filter with Auto Drain plus Regulator with Gauge
AM40-2	4" Amplifier plus Filter with Auto Drain plus Regulator with Gauge
AM75-2	8" Amplifier plus Filter with Auto Drain plus Regulator with Gauge
AM125-2	Stainless Steel Shim, .002" for AM 75
SH75-2	Stainless Steel Shim, .003" for AM 10
SH10-3	Stainless Steel Shim, .002" for AM 20
SH20-2	Stainless Steel Shim, .003" for AM 20
SH40-2	Stainless Steel Shim, .002" for AM 40
SH40-3	Stainless Steel Shim, .003" for AM 40
SH75-2	Stainless Steel Shim, .002" for AM 75

Using Model AM20 Air Amplifiers to cool castings, cooling time was reduced by 20%

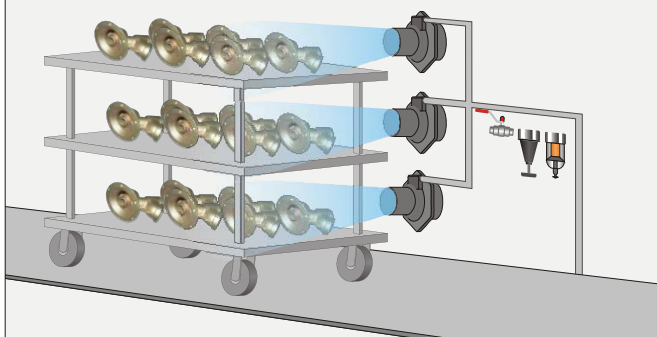

Two Model AM40 Air Amplifiers vent fumes from a tank quickly & efficiently

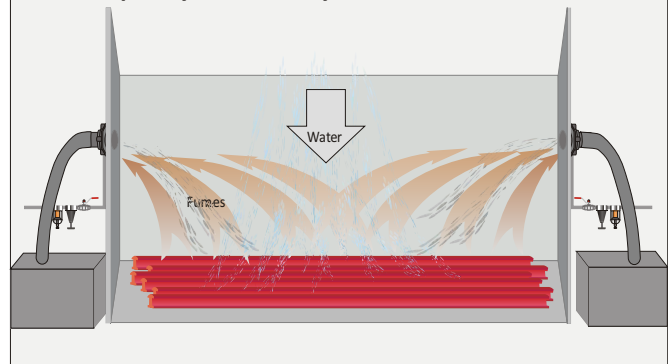

**ADJUSTABLE AIR AMPLIFIER - HOW IT WORKS:**

A large volume of surrounding air is induced into the Amplifier at point (A) by the action of a small amount of compressed air which enters the annular chamber at point (B) that is then throttled through a small ring Nozzle at high velocity and into the inside of the Amplifier over a coanda profile. The compressed air stream clings to the coanda profile as it enters the inside walls of the Amplifier and thereby creating a vacuum that induces the outside air converting the pressure into amplified airflow. The amplified airflow leaves at the exit at point (C). Airflow is further amplified downstream at point (D) by entraining additional air from the surroundings at the exit.

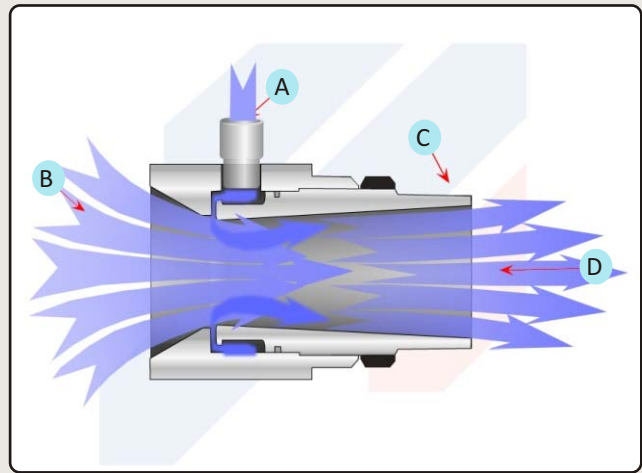

**ADJUSTABLE AIR AMPLIFIER SPECIFICATIONS:**

Normally set to .002" (.05mm) gap if greater air force is required, the gap is adjustable. The first two sizes of adjustable air amplifiers come in two versions – unmarked regular versions and marked to gauge the gap setting from 0 to 1.5 mm.

**ADJUSTABLE AIR AMPLIFIER RATIOS (APPROX.)**

Models 40001, 40001G and 40001S: 15:1

Models 40002, 40002G and 40002S: 16:1

Models 40003 and 40003S: 17:1

Model	OUTSIDE DIAMETER OF OUTLET	A	B	C	D	E	F	G	H* NPT
40001, 40001G, 40001S	1 1/4"	2.0	1.25	1.0	.98	1.38	1.88	2.88	1/4"
	19mm	50.8	31.8	25.4	24.9	35	47.8	73.2	
40002, 40002G, 40002S	2"	3.0	2.0	1.06	1.64	1.5	2.25	3.25	3/8"
	51mm	76.2	50.8	26.9	41.7	38	57.2	82.6	
40003, 40003S	4"	5.5	4.0	1.5	3.02	2.6	3.5	5.0	1/2"
	101mm	140	102	38.1	76.7	66	89	127	

\*BSP Threads or Adaptors can be supplied depending on country location.

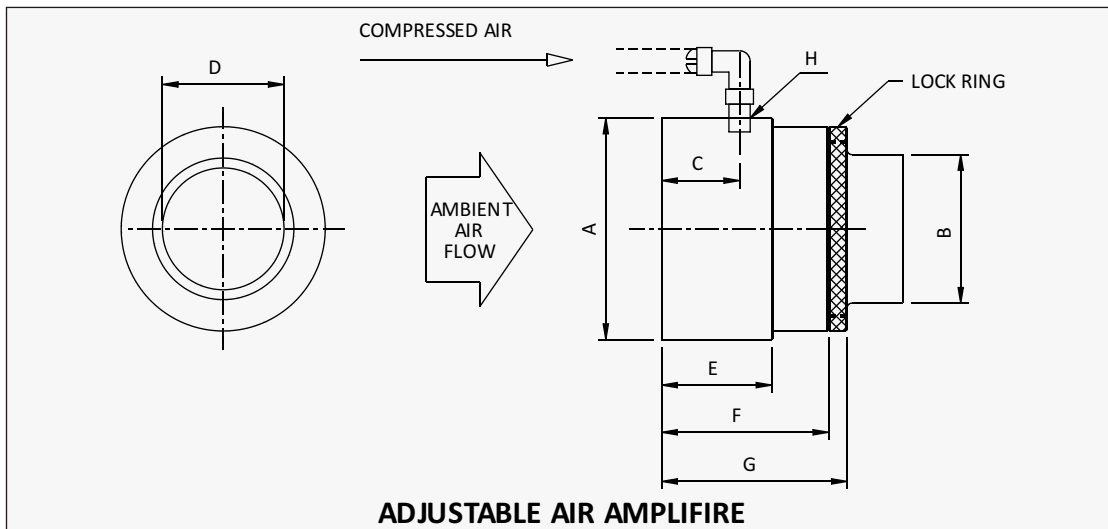

**ADJUSTABLE AIR AMPLIFIER**

**AIR AMPLIFIERS**



40001, 40001G and 40001S

AMPLIFICATION RATIO = 15:1 (SEE ADDENDUM - I)

**Pressure vs. Air Consumption for Model 40001, 40001G and 40001S Adjustable Air Amplifier**

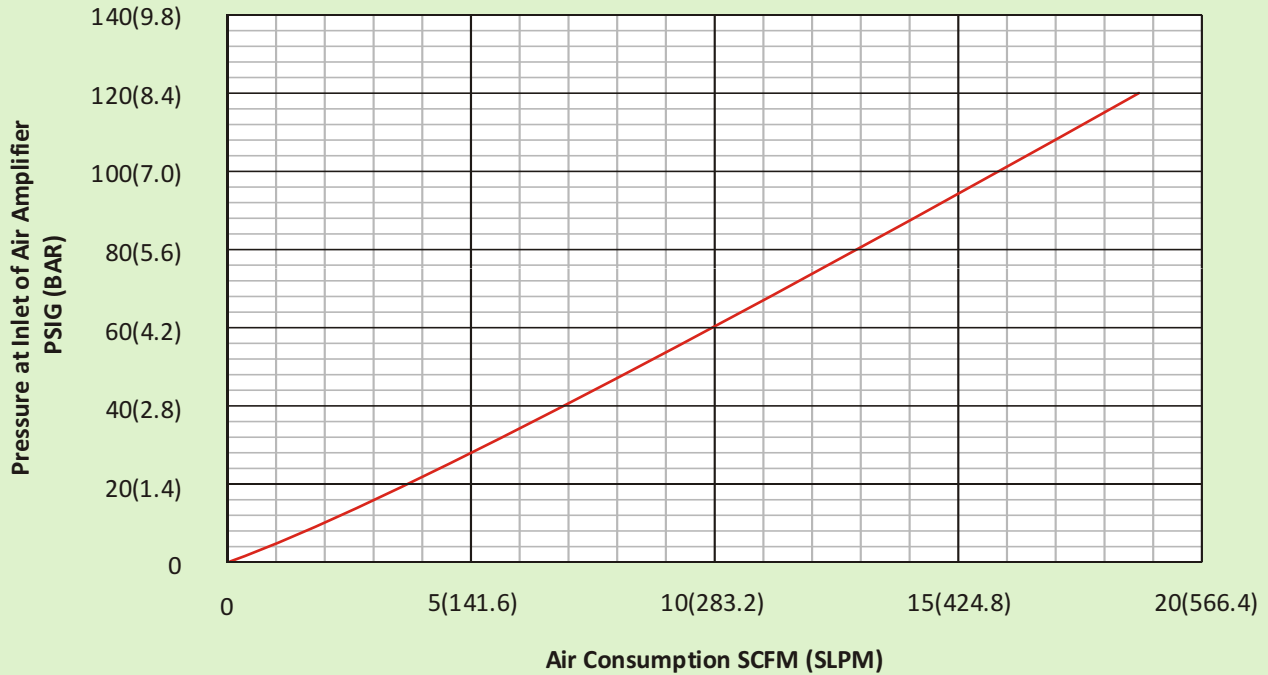

**Pressure vs. Air Flow At Outlet for Model 40001, 40001G and 40001S Adjustable Air Amplifier**

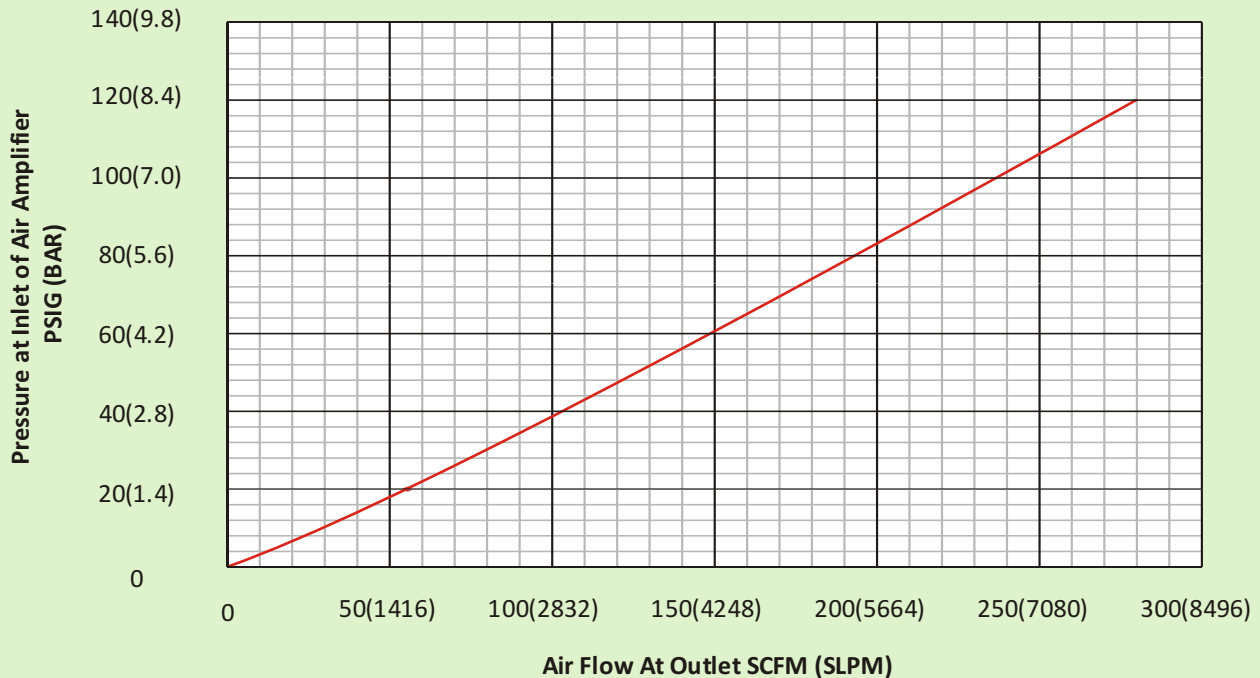

40001, 40001G and 40001S

**Pressure vs. Velocity At Outlet for Model 40001, 40001G and 40001S Adjustable Air Amplifier**

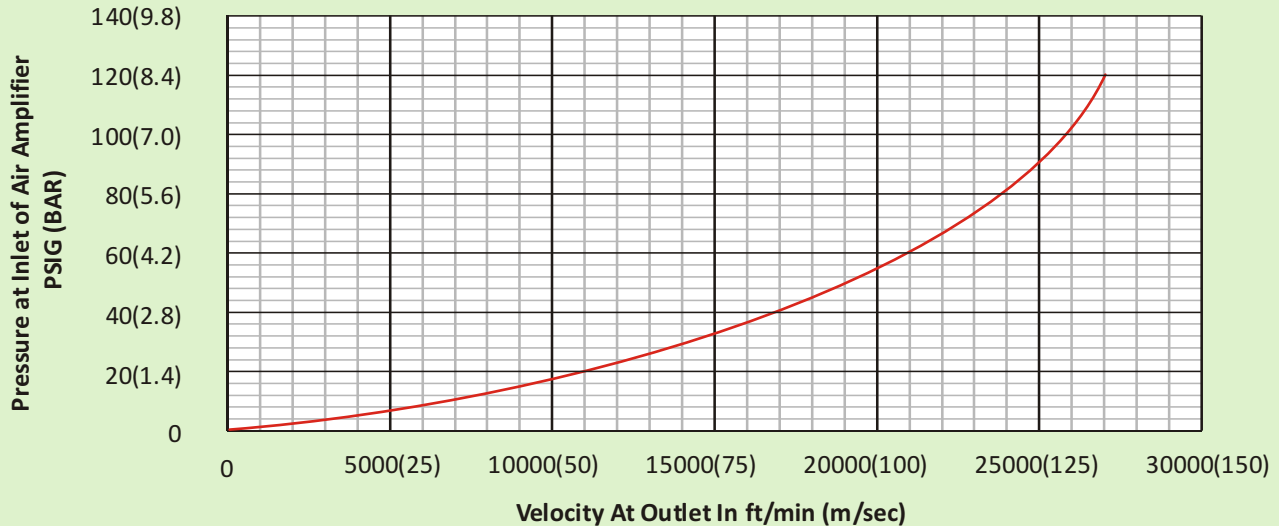

**Pressure vs. Velocity 12" From Outlet for Model 40001, 40001G and 40001S Adjustable Air Amplifier**

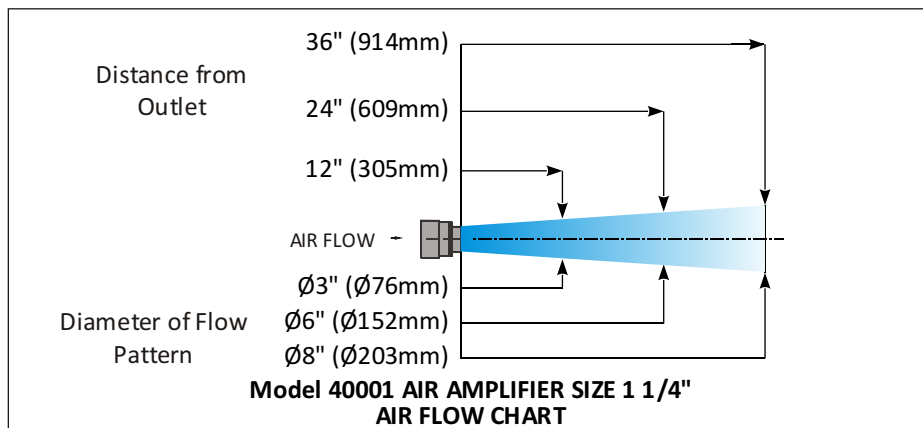
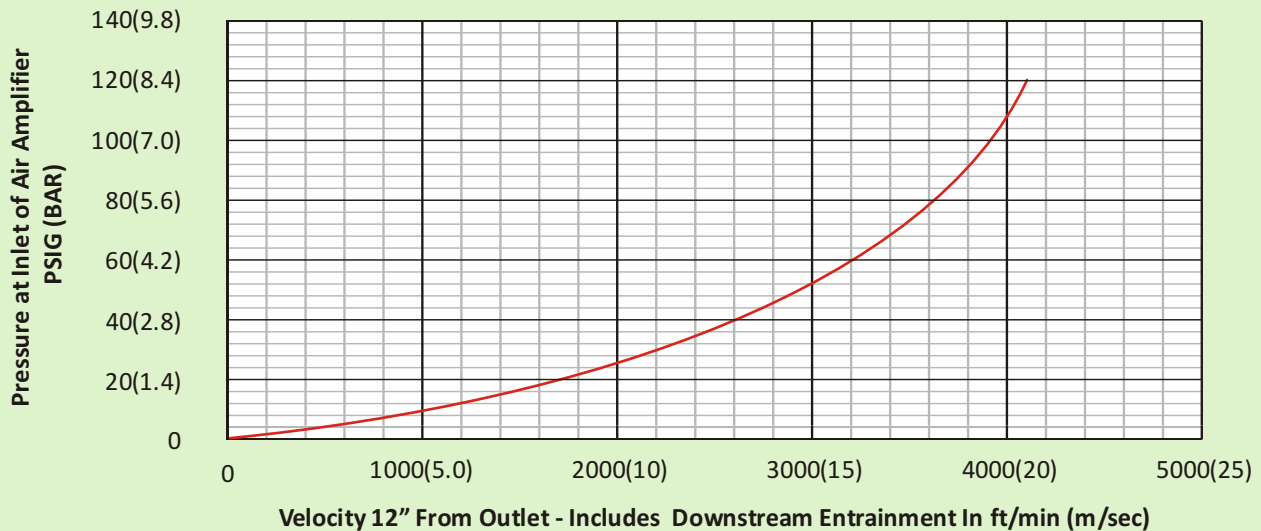

**AIR AMPLIFIERS**





40002, 40002G & 40002S

AMPLIFICATION RATIO = 16:1 (SEE ADDENDUM - I)

**Pressure vs. Air Consumption for Model 40002, 40002G & 40002S Adjustable Air Amplifier**

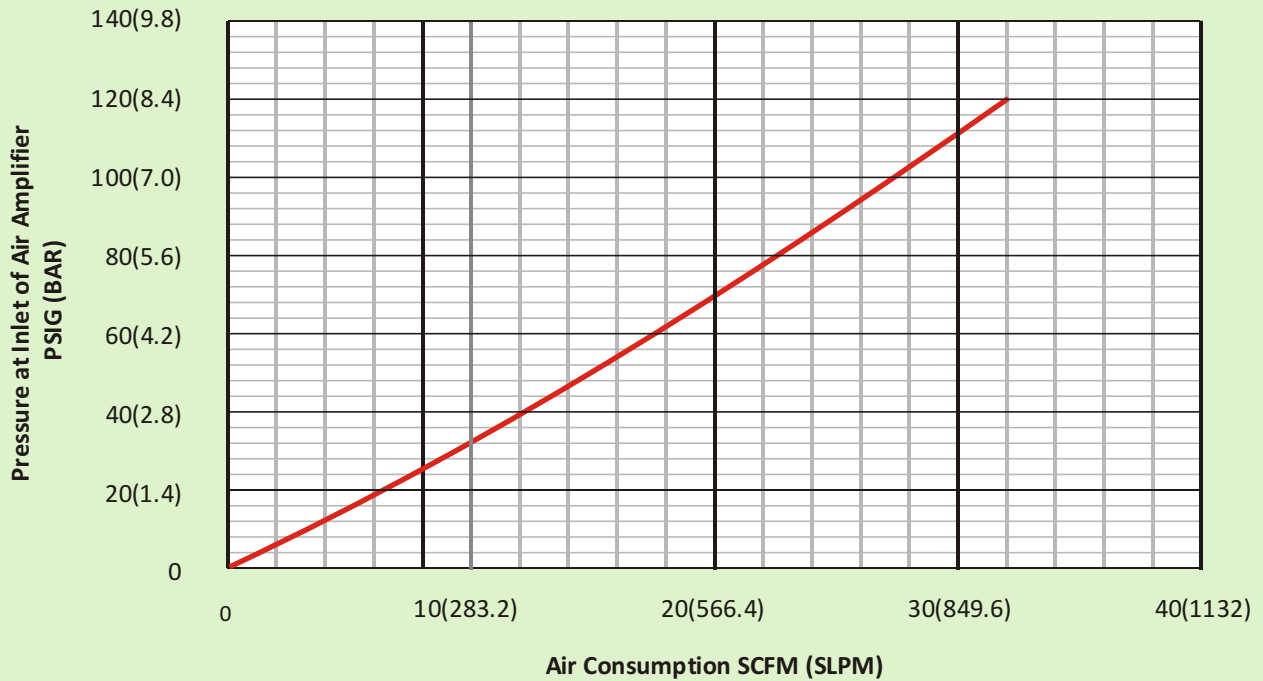

**Pressure vs. Air Flow At Outlet for Model 40002, 40002G & 40002S Adjustable Air Amplifier**

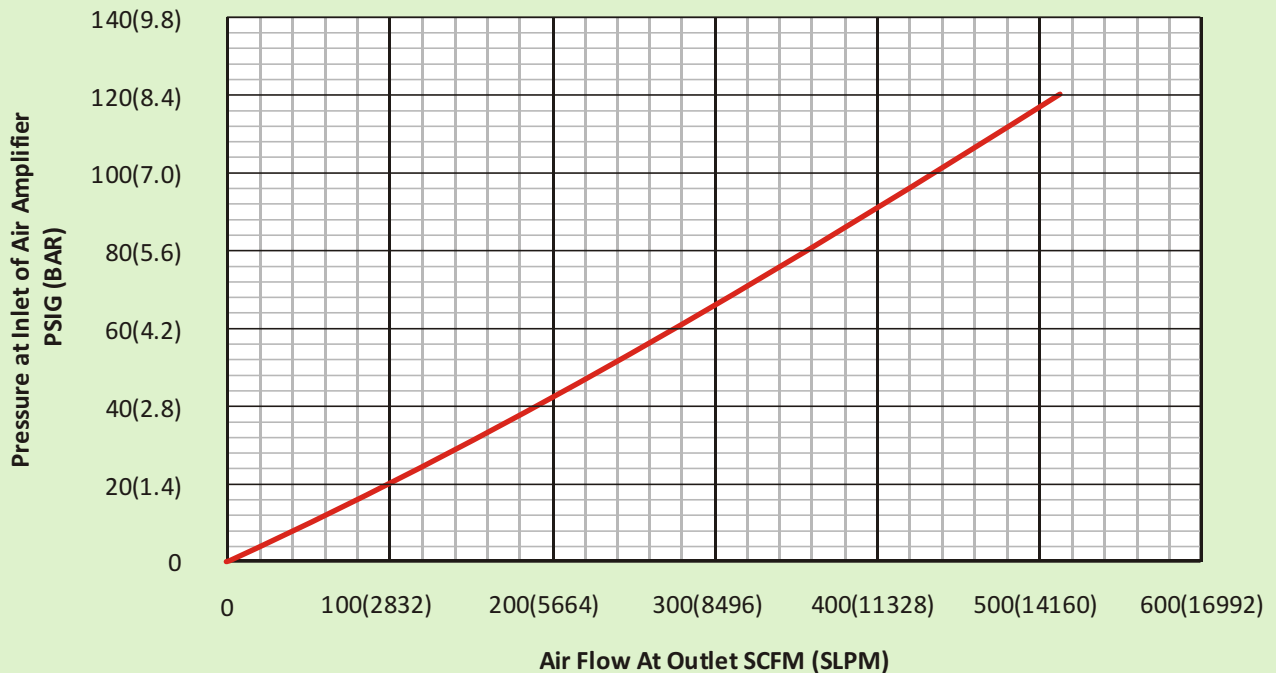

**40002, 40002G & 40002S**

**Pressure vs. Velocity At Outlet for Model 40002, 40002G & 40002S Adjustable Air Amplifier**

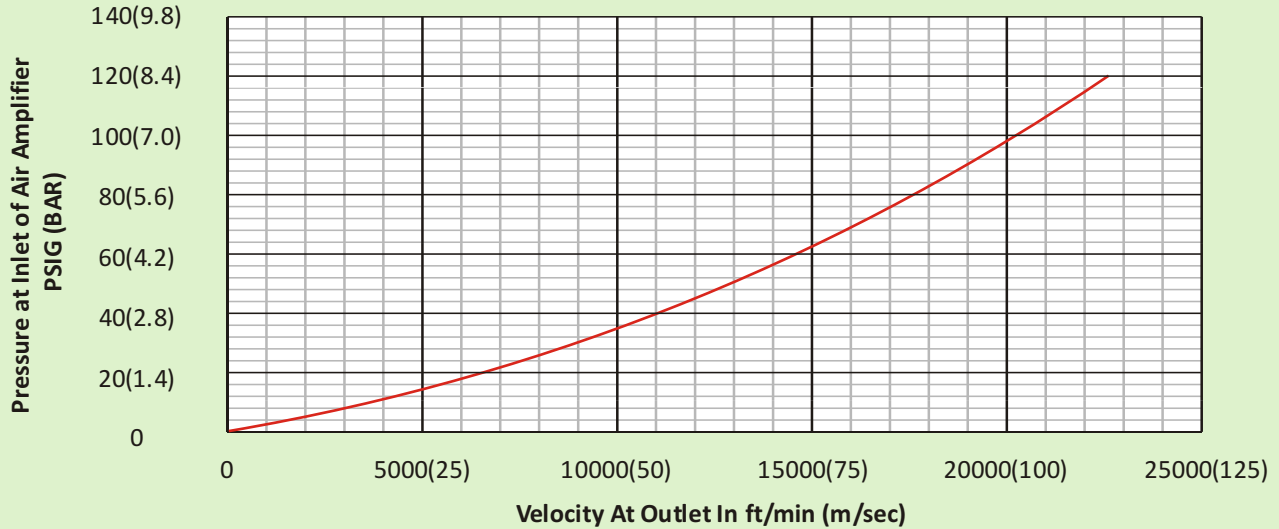

**Pressure vs. Velocity 12" From Outlet for 40002, 40002G & 40002S Adjustable Air Amplifier**

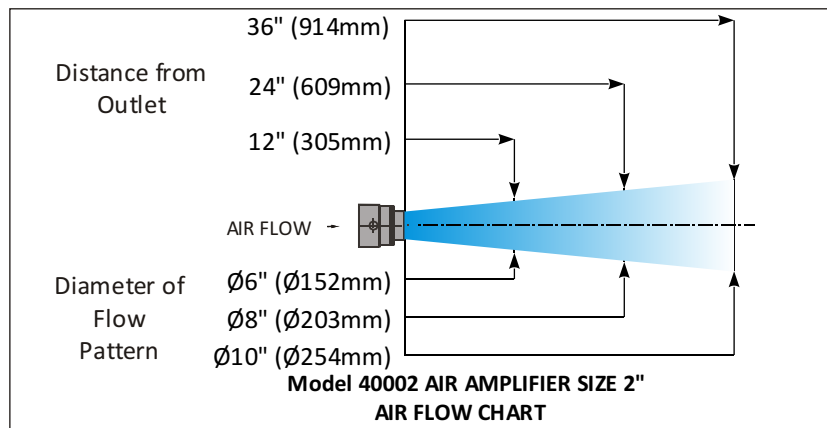
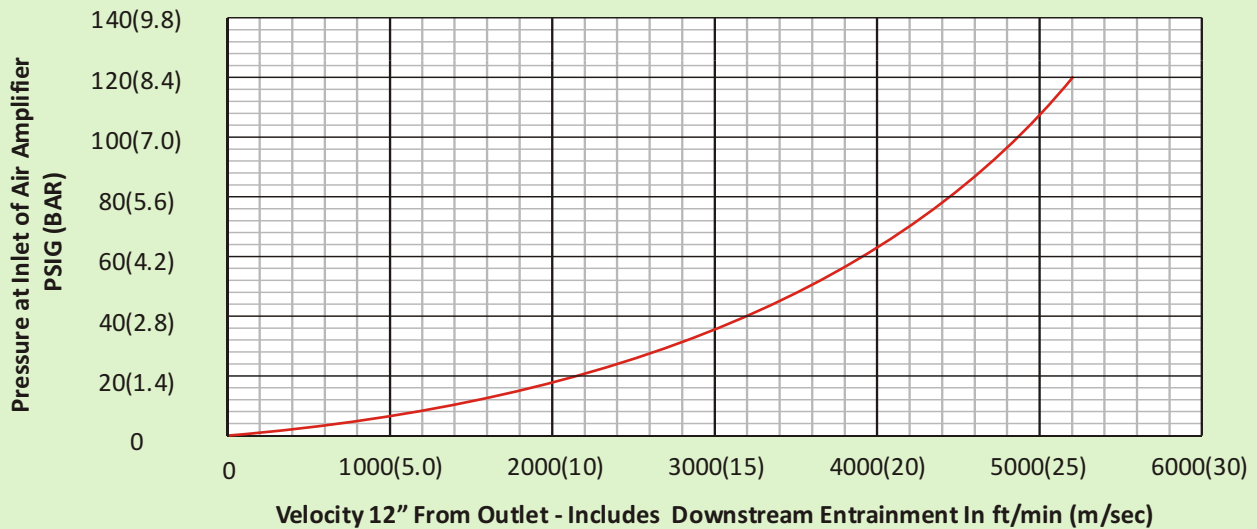

**AIR AMPLIFIERS**



40003 & 40003S

AMPLIFICATION RATIO = 17:1 (SEE ADDENDUM - I)

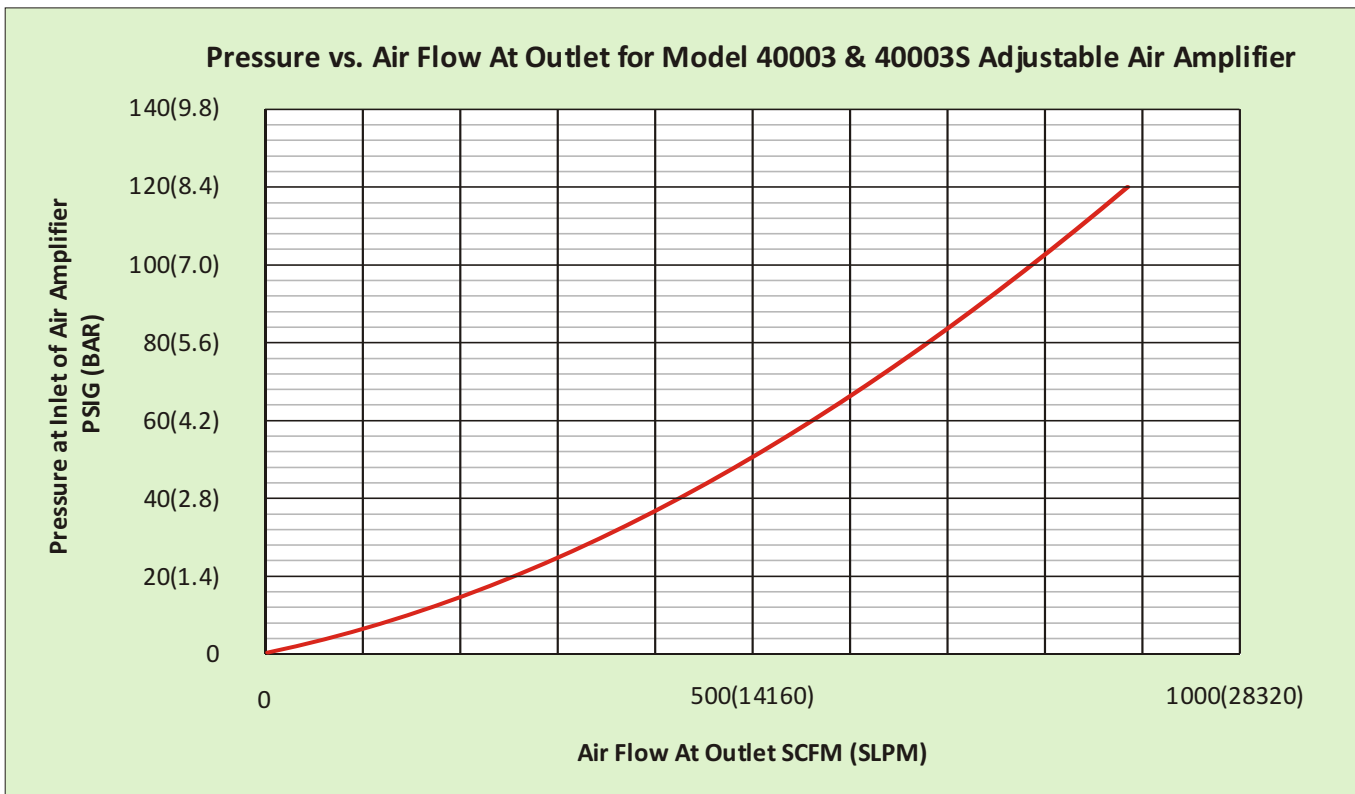
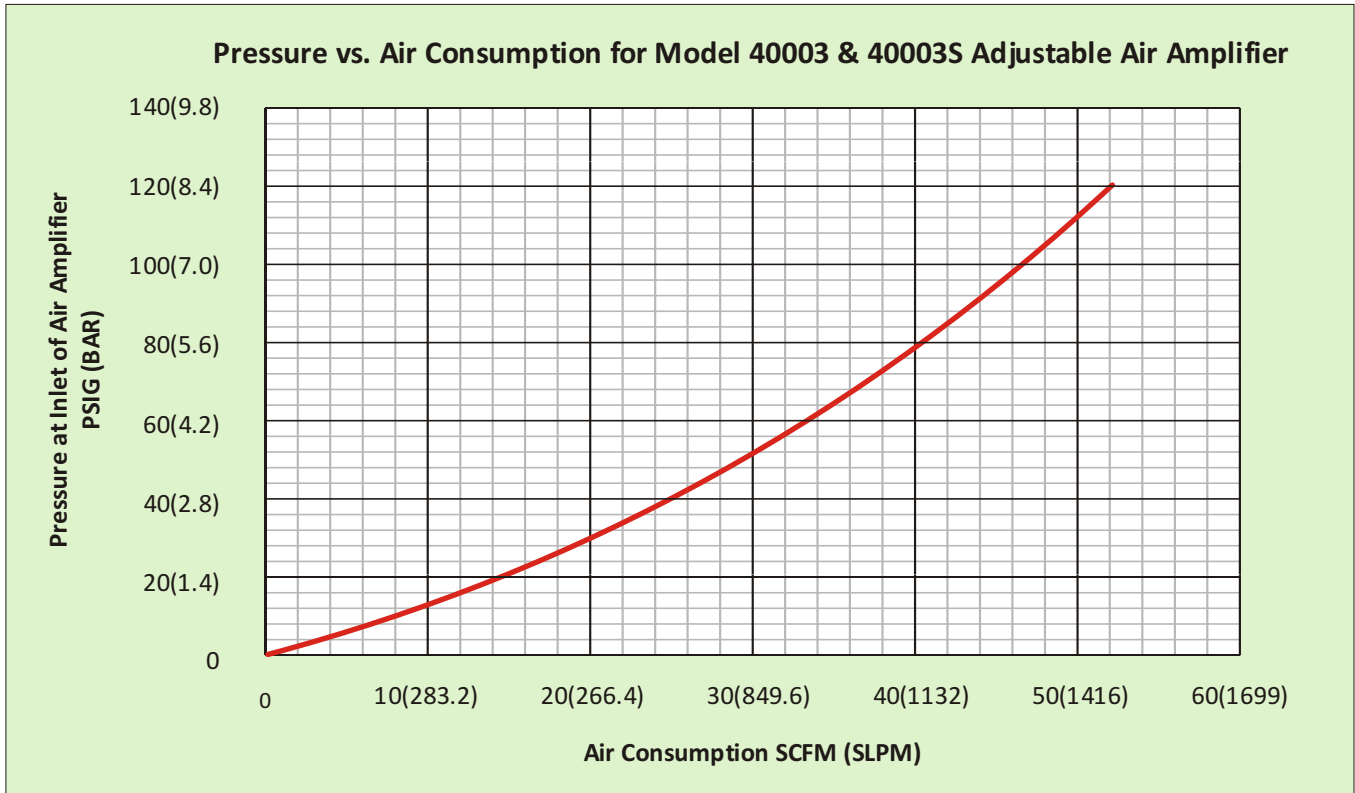

**40003 & 40003S**

**Pressure vs. Velocity At Outlet for Model 40003 & 40003S Adjustable Air Amplifier**

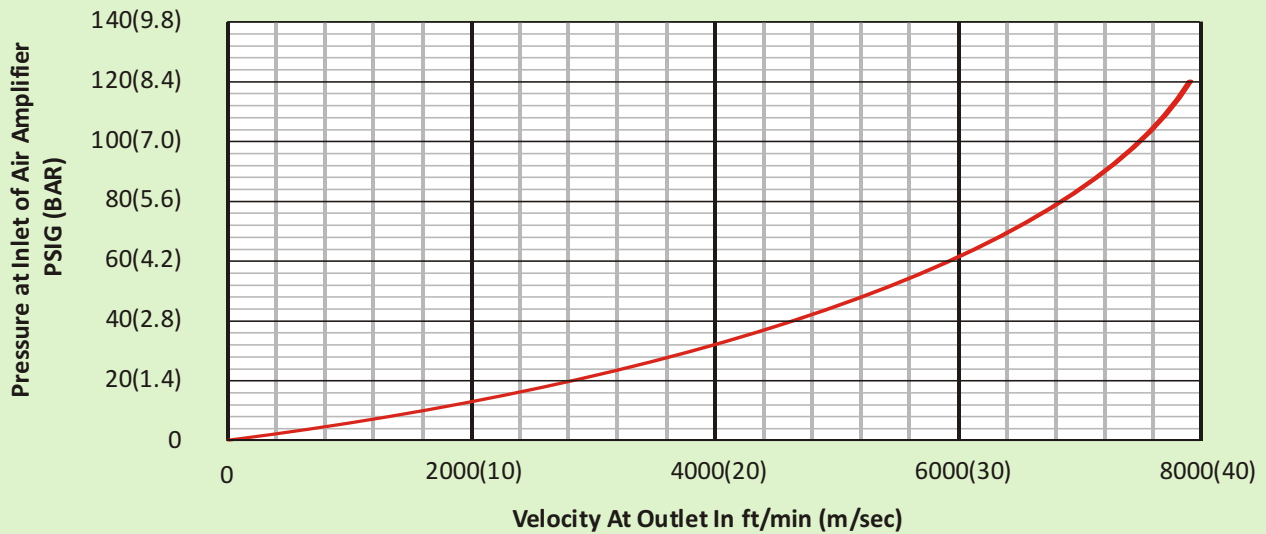

**Pressure vs. Velocity 12" From Outlet for Model 40003 & 40003S Adjustable Air Amplifier**

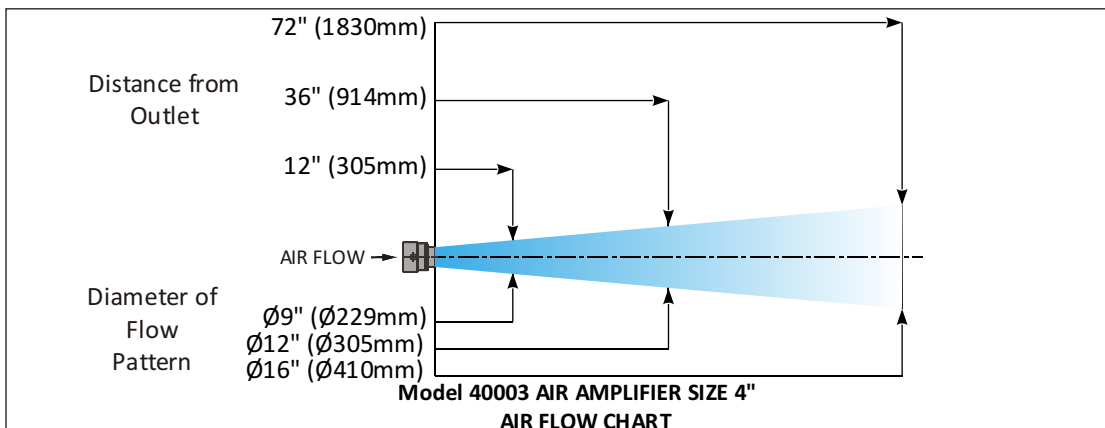
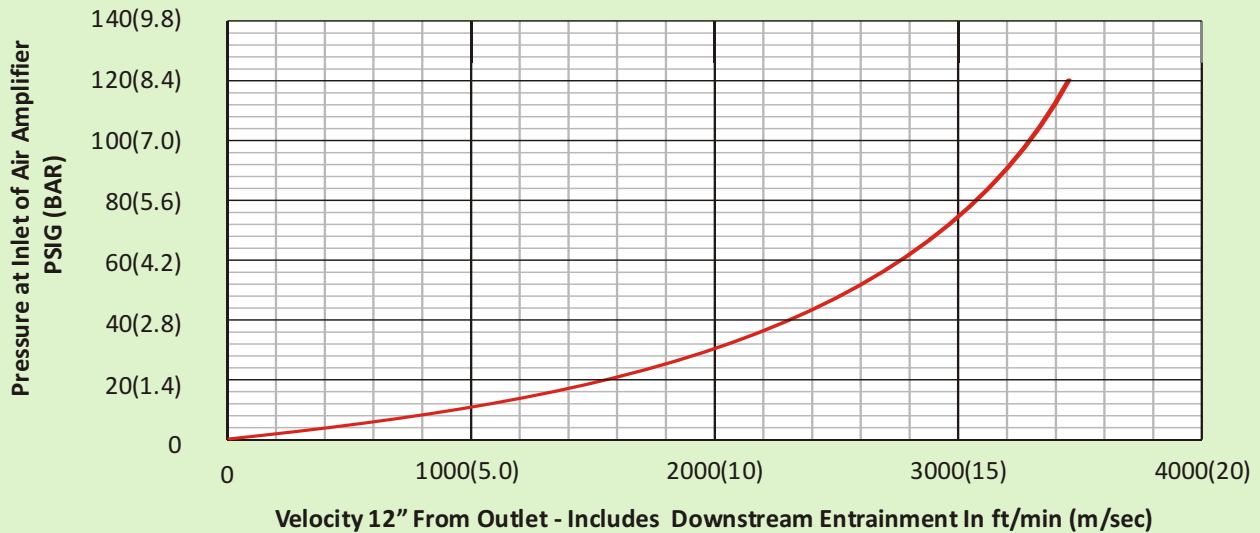

**AIR AMPLIFIERS**





The Adjustable Air Amplifier can be adjusted to provide the blow-off force and/or vacuum required for any particular application. Made of anodized aluminum or stainless steel for corrosive and high temperature applications the unit offers flexibility in applications.

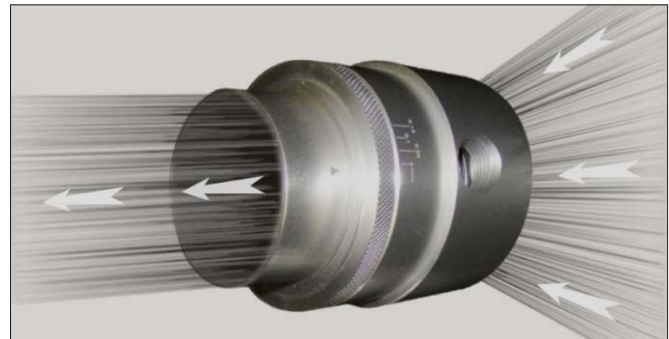

The Gauged Adjustable Air Amplifier with marking to indicate the settings from 0 to 1.5 mm comes in anodized aluminum for applications where accurate gap control is required. As with the regular adjustable unit the gaps are locked into place with a lock ring.

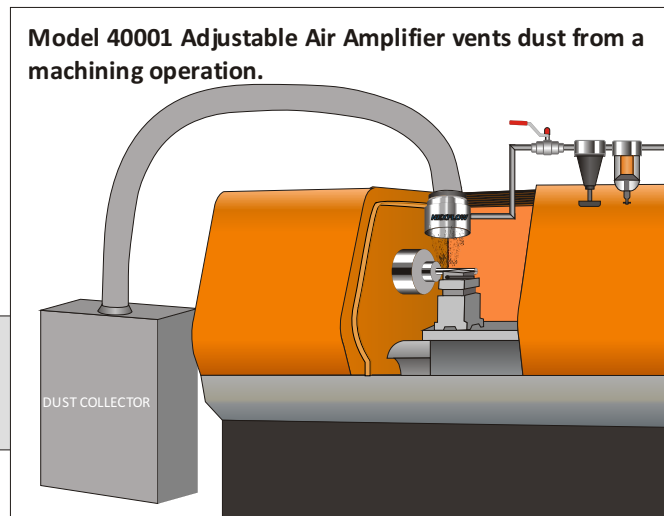
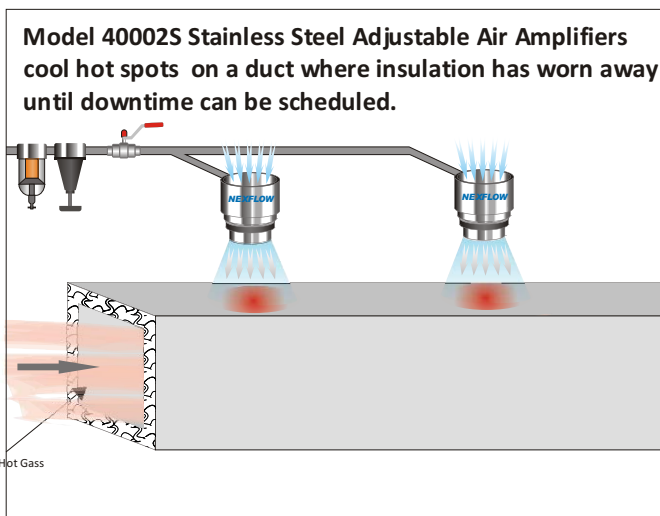

**ADJUSTABLE AIR AMPLIFIERS - ALUMINUM**

PART NO.	DESCRIPTION
40001	1-1/4" Adjustable Aluminum Air Amplifier
40002	2" Adjustable Aluminum Air Amplifier
40003	4" Adjustable Aluminum Air Amplifier
41001	1-1/4" Adjustable Aluminum Amplifier plus Filter with Auto Drain
41002	2" Adjustable Aluminum Amplifier plus Filter with Auto Drain
41003	4" Adjustable Aluminum Amplifier plus Filter with Auto drain
42001	1-1/4" Adjustable Aluminum Amplifier plus Filter with Auto Drain plus Regulator with Gauge
42002	2" Adjustable Aluminum Amplifier plus Filter with Auto Drain plus Regulator with Gauge
42003	4" Adjustable Aluminum Amplifier plus Filter with Auto Drain plus Regulator with Gauge

**ADJUSTABLE AIR AMPLIFIERS - GAUGED SETTINGS**

PART NO.	DESCRIPTION
40001G	1-1/4" Adjustable Aluminum Air Amplifier with Gauged Settings
40002G	2" Adjustable Aluminum Air Amplifier with Gauged Settings
41001G	1-1/4" Adjustable Aluminum Air Amplifier with Gauged Settings plus Filter with Auto Drain
41002G	2" Adjustable Aluminum Air Amplifier with Gauged Settings plus Filter with Auto Drain
42001G	1-1/4" Adj. Aluminum Air Amplifier with Gauged Settings plus Filter with Auto Drain plus Regulator with Gauge
42002G	2" Adj. Aluminum Air Amplifier with Gauged Settings plus Filter with Auto Drain plus Regulator with Gauge

**ADJUSTABLE AIR AMPLIFIERS - STAINLESS STEEL**

PART NO.	DESCRIPTION
40001S	1-1/4" Adjustable Stainless Steel Air Amplifier
40002S	2" Adjustable Stainless Steel Air Amplifier
40003S	4" Adjustable Stainless Steel Air Amplifier
41001S	1-1/4" Adjustable Stainless Steel Amplifier plus Filter with Auto Drain
41002S	2" Adjustable Stainless Steel Amplifier plus Filter with Auto Drain
41003S	4" Adjustable Stainless Steel Amplifier plus Filter with Auto Drain
42001S	1-1/4" Adjustable Stainless Steel Amplifier plus Filter with Auto Drain plus Regulator with Gauge
42002S	2" Adjustable Stainless Steel Amplifier plus Filter with Auto Drain plus Regulator with Gauge
42003S	4" Adjustable Aluminum Steel Amplifier plus Filter with Auto Drain plus Regulator with Gauge

**AIR AMPLIFIERS**
